

# Service & Troubleshooting

Amana S-Series Service & Troubleshooting  
Technical Training Module TRV-7



Rest assured.  
It's an Amana® brand.



© 2023 Daikin Comfort Technologies North America, Inc.  
Amana® is a registered trademark of Maytag Corporation or its related companies and is used under license.  
All rights reserved.



# Disclaimer

---

This material provides technical information that is to only be used by appropriately trained and certified HVAC-R installers and technicians who have agreed to the terms and conditions available here at <https://www.daikincity.com/DaikinCityB2BTermsOfUse.html>. If you have not agreed to these terms and conditions, you may not use or view this material, and you assume responsibility for any injury or property, system or equipment damage which may result. If you have agreed to these terms, you also agree, by viewing or using this material, that this material, by its nature, cannot include a discussion of everything necessary to effect a proper installation or repair of HVAC-R equipment, nor can it address every possible scenario or environment a technician or installer may encounter. Accordingly, this material should not be considered as recommendations for best practices and will not be considered installation or repair instructions to the extent of any conflict with Daikin- or Goodman-issued manuals and specifications, or industry standards and regulations. Each installer or technician remains fully responsible for ensuring proper installation or repair of the HVAC-R equipment being worked on, and you remain fully responsible for any injury or property, system or equipment damage which may result from your installation. ©2023 Daikin Comfort Technologies North America, Inc., all rights reserved; recording, copying, or distribution of this material is prohibited without express written permission from Daikin.

Amana® is a registered trademark of Maytag Corporation or its related companies and is used under license. All rights reserved.

## Agenda

### System Status

Inverter Board and Components

Troubleshooting

Replacing Inverter Board

Emergency Modes

D-Checker

# Amana Smart Thermostat - Messaging

- Amana Smart Thermostat's messaging updates, confirms, and informs about selections you make during set-up and operation.
- There are four types of messages:
  - Status
  - Alerts
  - Reminders and Prompts
  - Learn more/tips

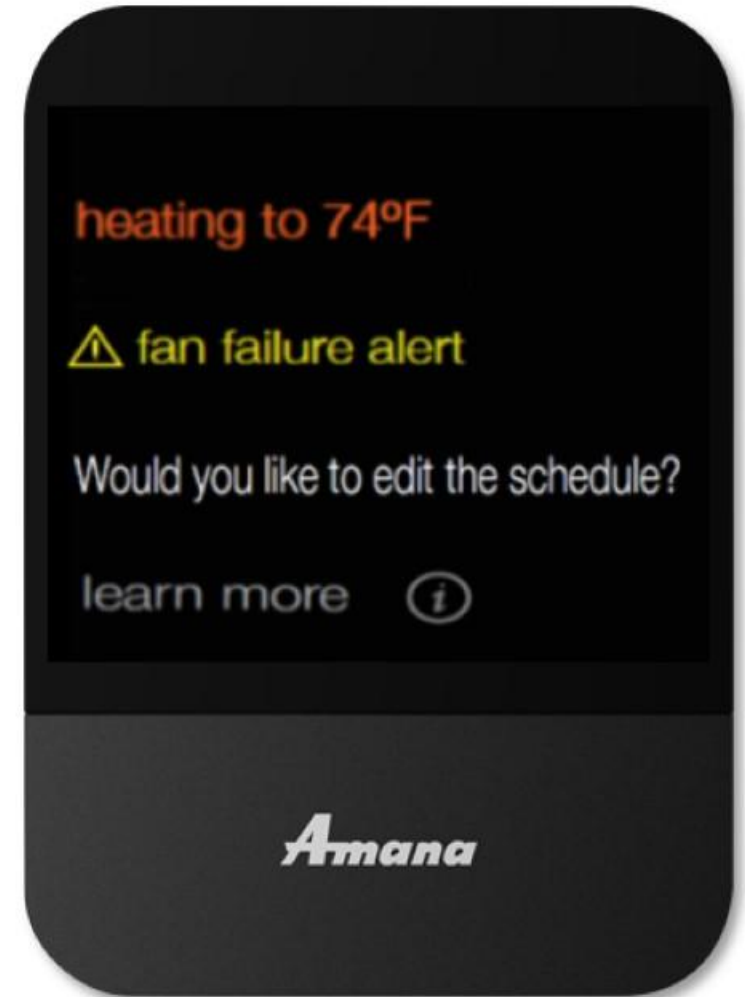

Note: Alerts have priority over all other messages in the system.

# Dealer Navigation

## Dealer edit

- Navigating to dealer edit will allow you to access or revisit the installer set-up screen.
- Advanced adjustments to the Amana Smart Thermostat will be made here.

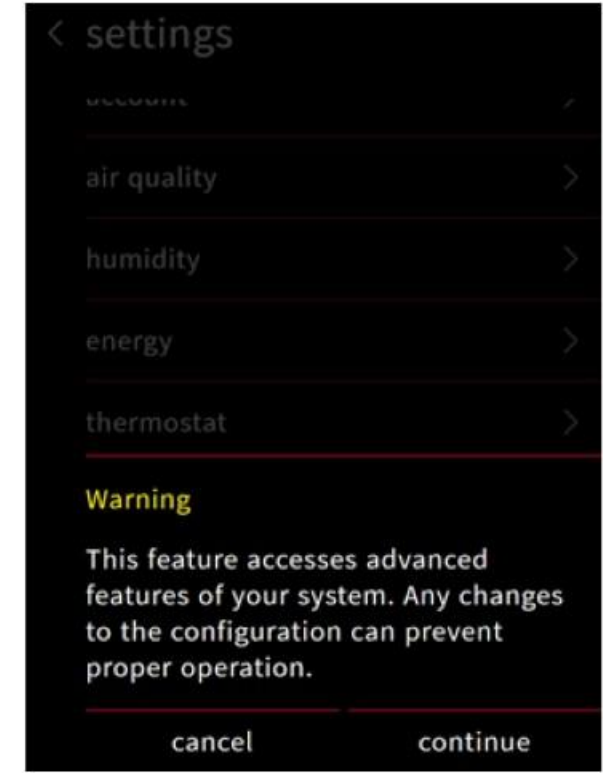
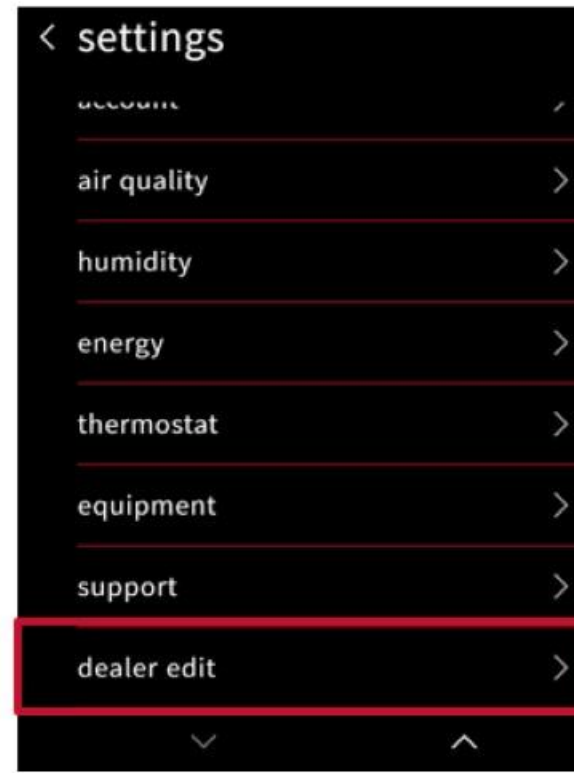
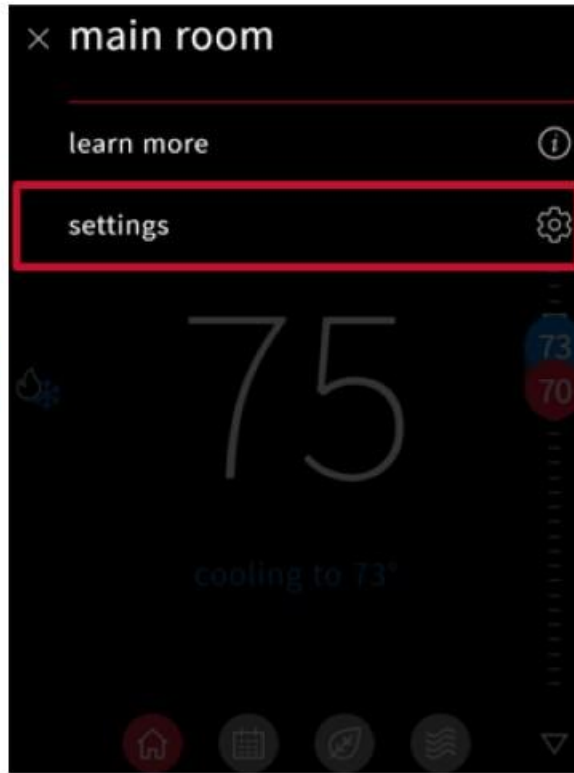
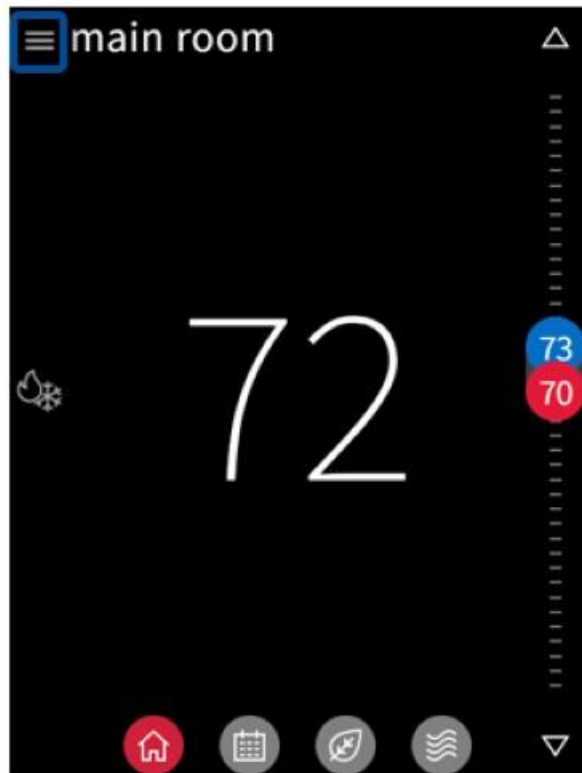

# Dealer Navigation

- Acknowledging the prompt enables you to tap the learn more icon.
- The icon displays the installer code, giving you access to the installer set-up screens.

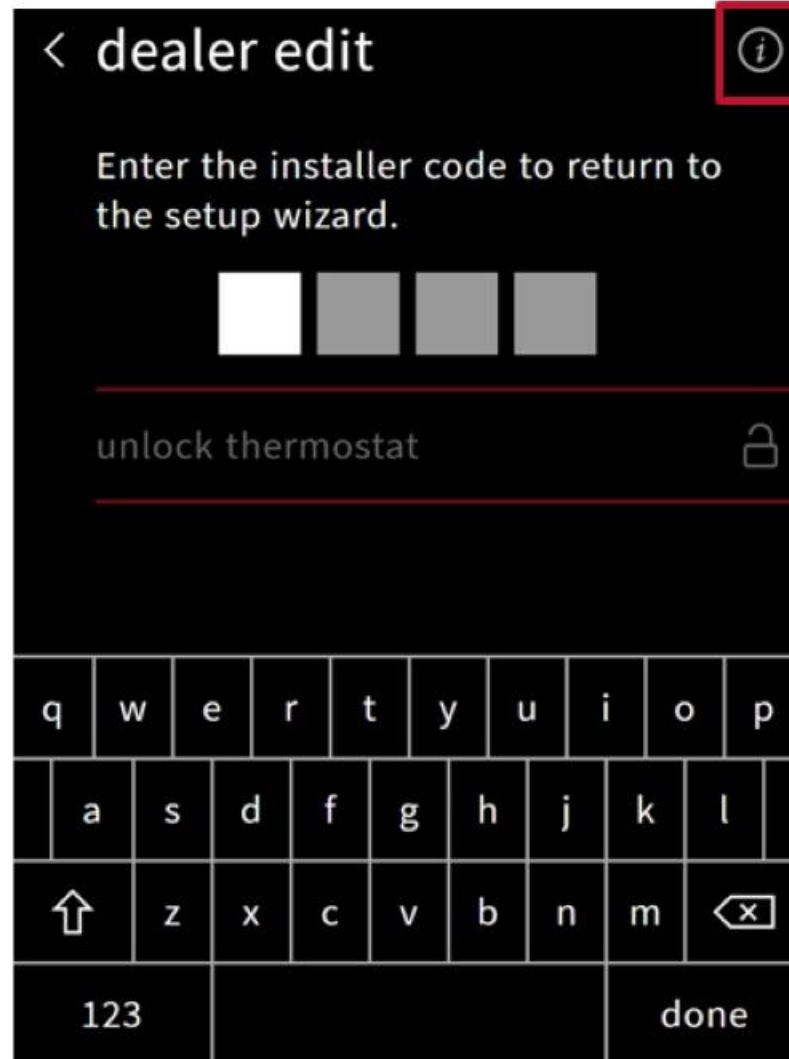



## Status

- The status menu displays data pertaining to the selected equipment.
- The scrollable list can be accessed any time by returning to the installer set-up screen.

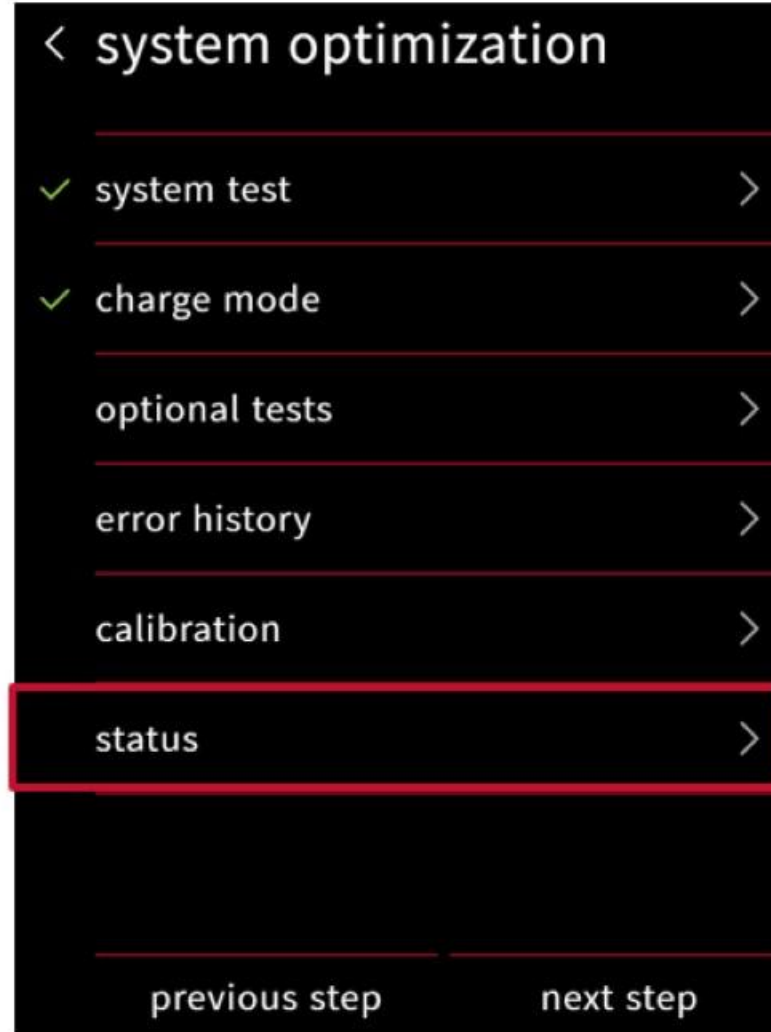



- The error history menu stores errors from most recent to least recent.
  - 10 thermostat and 10 equipment error codes can be stored.
  - Each error entry includes an error code.
    - A timestamp along with the equipment type that generated the error, and a brief error description is displayed.

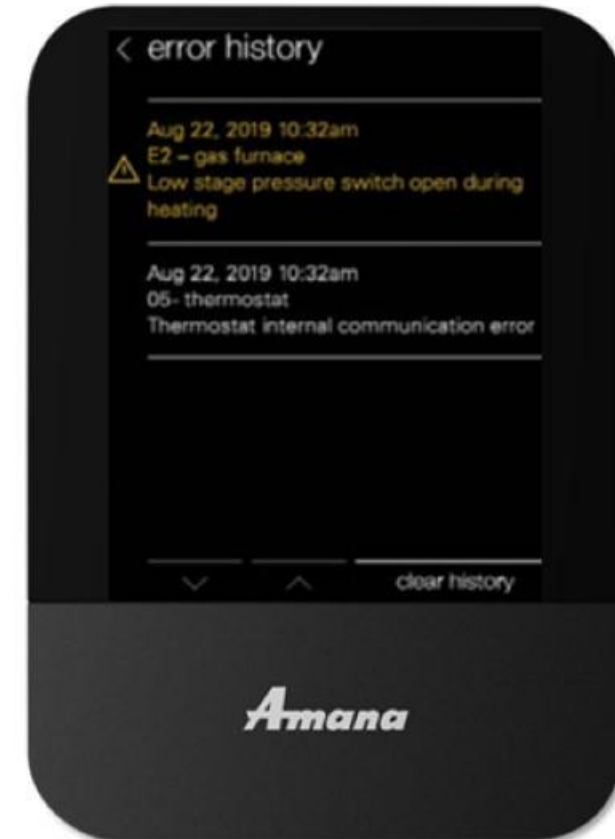
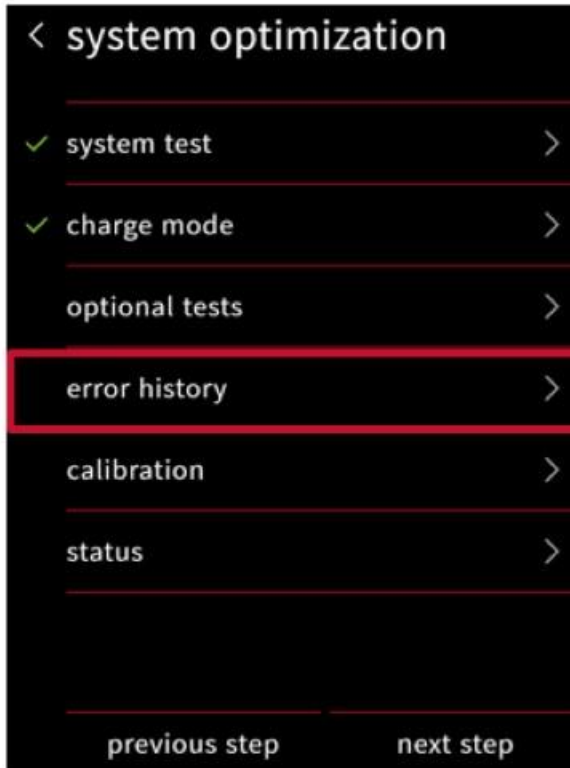
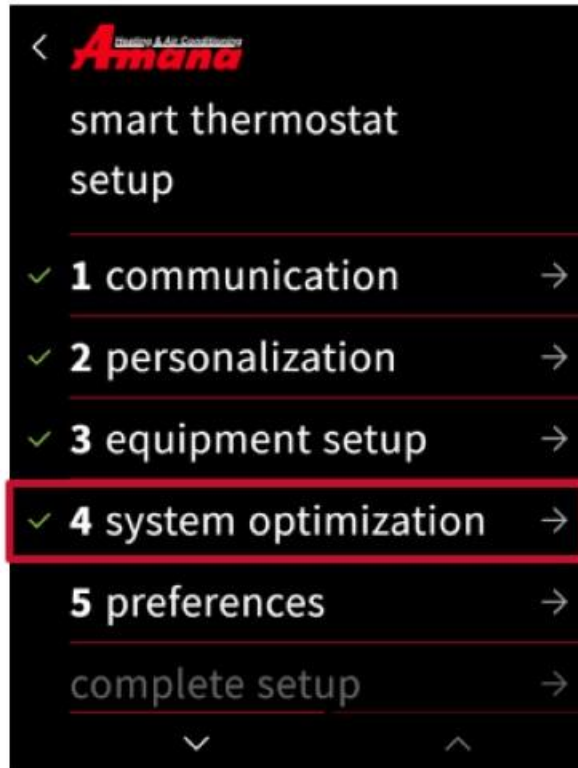

# Error Codes

- A 3-digit, 7 segment display can be used for reading errors, error history, and monitoring and setting up the outdoor unit.
- The advantage to this feature is for the technician to read error codes at the outdoor unit, without having to enter the home.

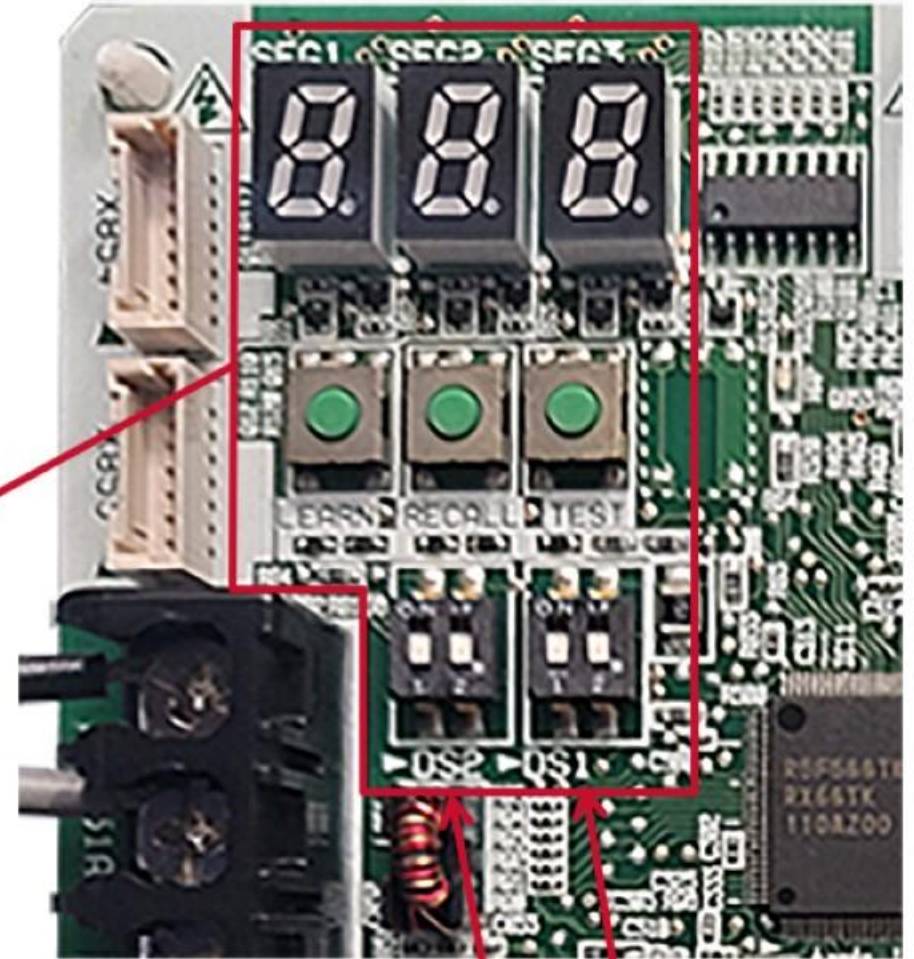
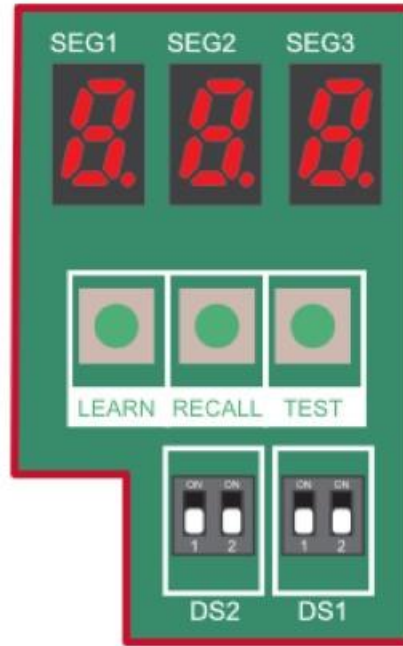

**NOTE:** DS2 DS1

# Error Codes

Refer to the OUTDOOR UNIT ERROR CODE chart in the service manual

- There are 5 modes which can be accessed by using the setting display: FAULT CODE, FAULT HISTORY, MONITORING, SETTING MODE 1 and SETTING MODE 2.

Mode	Function	Display Screen Number
Fault Code Display	Present fault (if any)	0 (Default)
Fault Code History	6 Recent faults stored	1
Monitoring Mode	*Monitors system values	2
Setting Mode 1	*Can change system settings	3
Setting Mode 2	*Can change system settings	4

# Error Codes

Steps to reach current faults and fault history.

- Screen Zero: The current fault will be displayed on the screen when you approach the unit and remove the panel.
  - Screen One: Fault history. The last 6 faults will be stored.
    - Hold the RECALL button for 5 seconds.
- A** The first screen that appears is 1.00.
- B** Press RECALL again for one second and the first fault will appear.
- C** Press RECALL again for one second and the 2nd fault will appear.

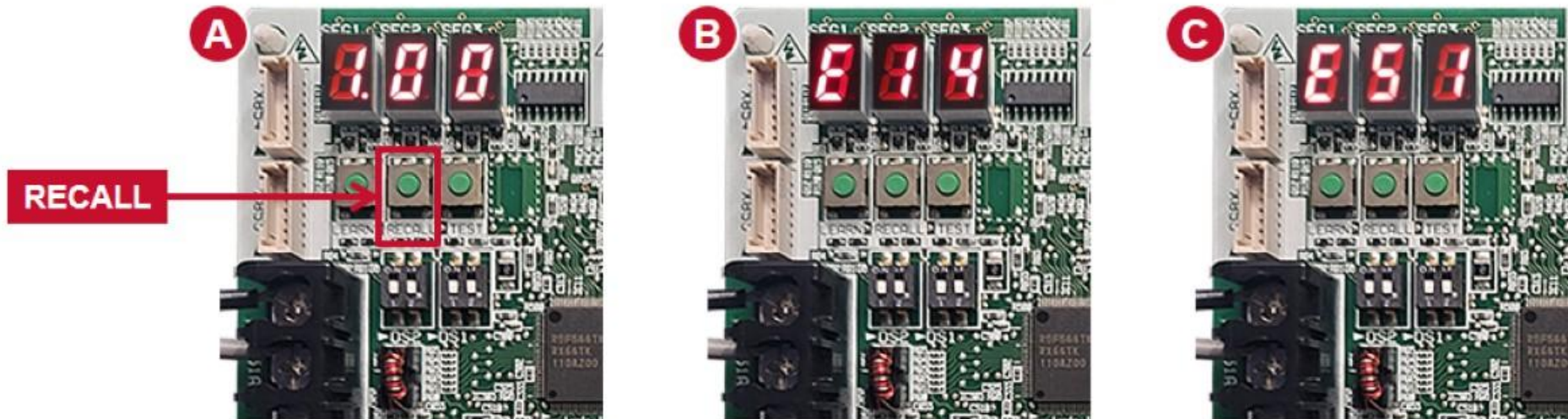

# Error Codes

## Return to home screen

- Hit the LEARN button for one second and the last fault will disappear.
- The screen will remain blank until prompted again.
- Refer to the service manual for a complete list of error codes.

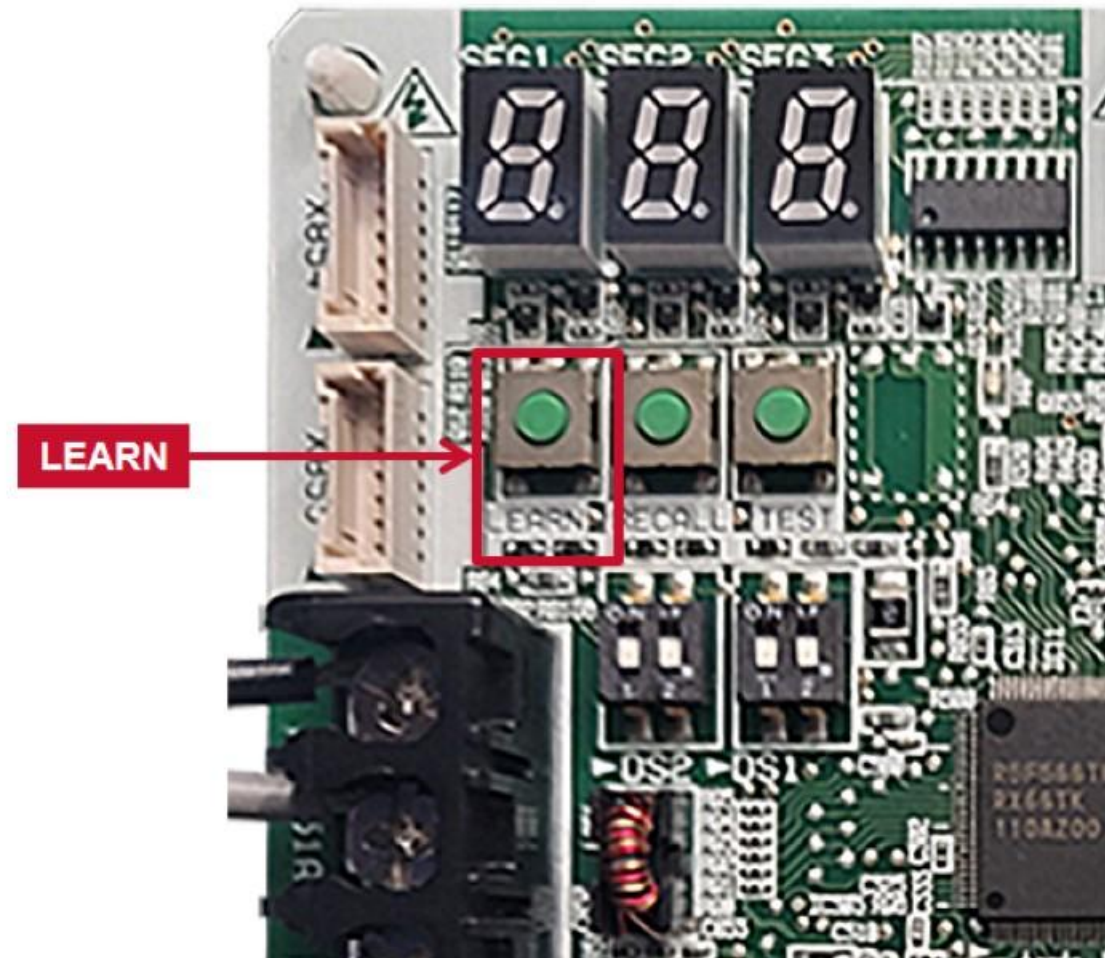

## Agenda

System Status

**Inverter Board and Components**

Troubleshooting

Replacing Inverter Board

Emergency Modes

D-Checker

# PCB (1.5-3-ton)



## Main PCB

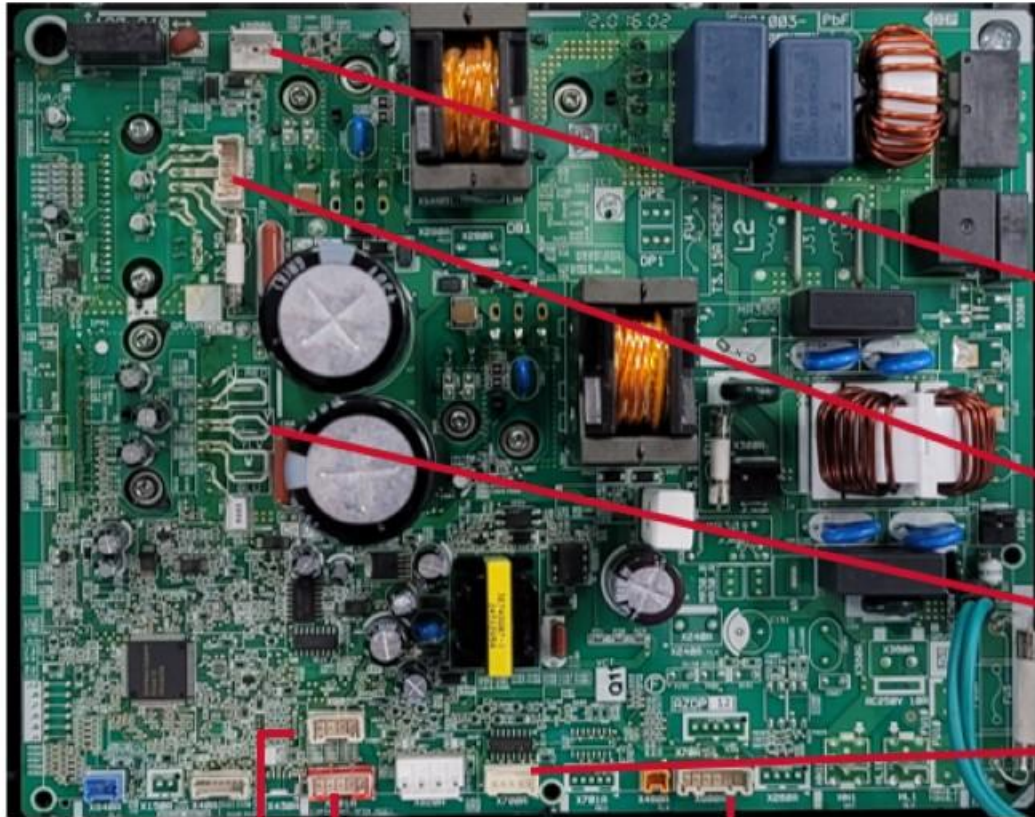

Solenoid coil  
(Heat pump)



Condenser fan

Compressor  
(U,V,W)

OD EEV

Ambient  
thermistor

Defrost and coil  
thermistor

Discharge, liquid, and  
suction thermistor

## Service PCB

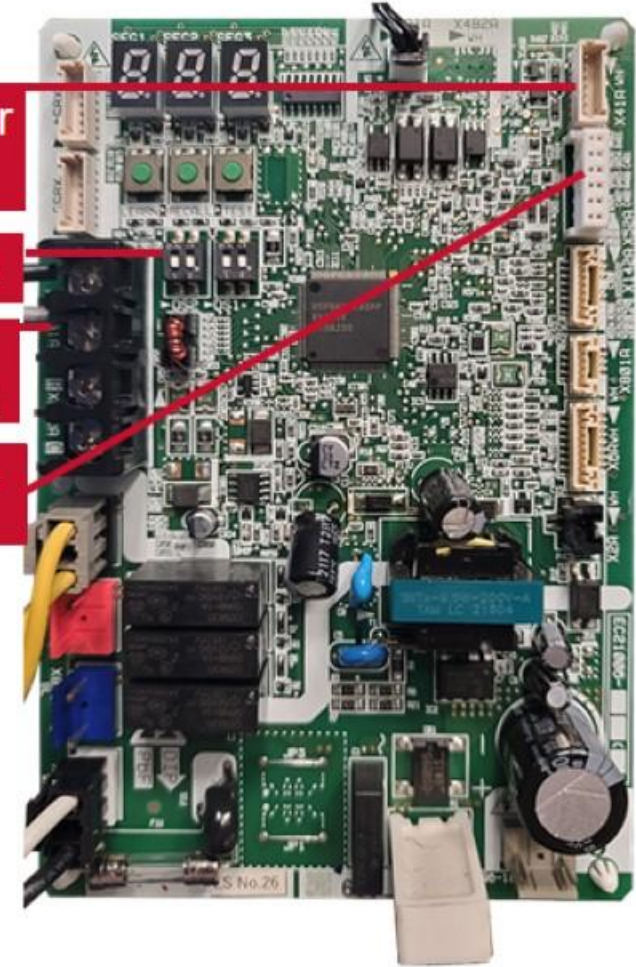

D-Checker  
port

DS1/DS2

Data  
connection

OD EEV

Smaller chassis models (1.5 - 3Ton) utilize a heat sink behind PCB.



Thermistor bank

Data connections

DS1/DS2

Reversing valve solenoid

IGBTs/  
Cooling Loop

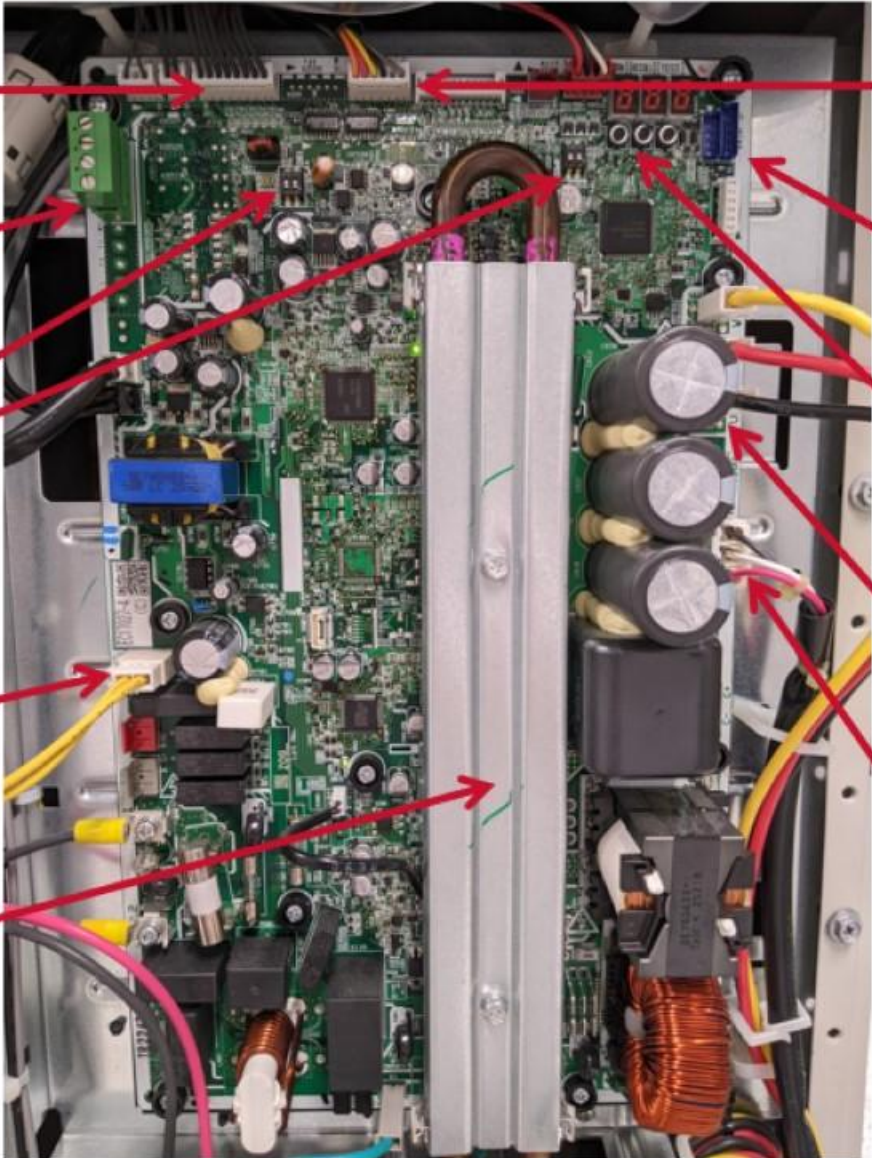

OD EEV

D-Checker port

7 Seg display &  
push buttons

Compressor terminals

OD fan motor



## Agenda

System Status

Inverter Board and Components

**Troubleshooting**

Replacing Inverter Board

Emergency Modes

D-Checker

# Discharging Inverter Board



## WARNING

Avoid contact with the charged area.

- Never touch the charged area before confirming that the residual voltage is 50 volts or less.
1. Shut down the power and leave the control box for **10 minutes**.
  2. Make sure to **touch the earth ground terminal to release the static electricity from your body** (to prevent failure of the PC board).
  3. Measure the residual voltage in the specified measurement position using a VOM while paying attention not to touch the charged area.
  4. Immediately after measuring the residual voltage, **disconnect the connectors of the outdoor unit's fan motor**. (If the fan blade rotates by strong wind blowing against it, the capacitor **will be charged**, causing the **danger of electrical shock**.)



## WARNING

**HIGH VOLTAGE!**  
DISCONNECT ALL POWER BEFORE  
SERVICING OR INSTALLING.  
MULTIPLE POWER SOURCES  
MAY BE PRESENT. FAILURE TO DO  
SO MAY CAUSE PROPERTY DAMAGE,  
PERSONAL INJURY OR DEATH.



## CAUTION

WHEN REPLACING THE ELECTRICAL BOARD,  
DO NOT TOUCH THE HATCHED AREAS.  
BEFORE INSTALLING THE NEW ELECTRICAL  
BOARD, BE SURE TO WIPE THE GREASE OFF  
THE REFRIGERANT TUBING. EXERCISE  
CAUTION TO NOT DAMAGE THE ELECTRICAL  
CONNECTIONS. DISCONNECT AS NEEDED.

**Read all warning labels before performing any service!**

# Discharging the Board



- Do not contact the circuit board until it has discharged.
  - Set meter to DC volts and place one lead on the solder pad for (C-) and one lead on the solder pad for (C+) to read the DC voltage.
  - Make sure to touch the earth ground terminal to release the static electricity from your body.
- Once the residual DC voltage is 50 volts or less, the board is considered safe. (preferred voltage is 10 VDC or less)

**NOTE:** It is recommended to power the system down for 15 minutes to allow the board to discharge naturally before making contact.

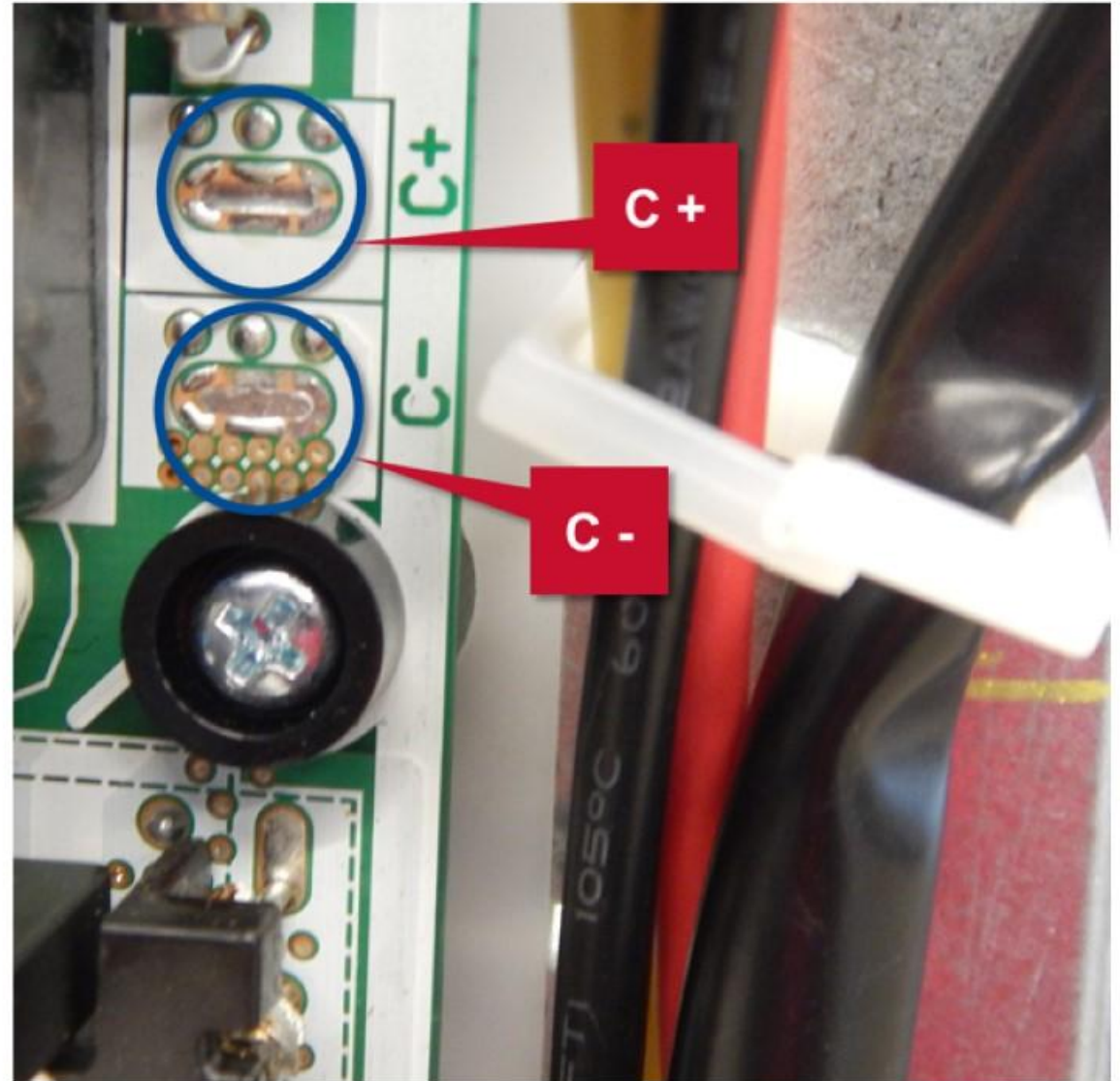

## Compressor ground test

- Disconnect all power to the unit and make sure all power legs are open.
- If a fuse, circuit breaker, or ground fault protective device has tripped, it's an indication that an electrical problem exists.
- Carefully remove the leads at the compressor terminals.
- Test for ground between compressor terminals and ground.
- If ground is indicated, replace the compressor.





## Testing compressor windings

- Remove the leads from the compressor terminals.
- Set meter to ohms and check between U-W, U-V, and V-W.
- If the windings do not test continuous, replace the compressor.

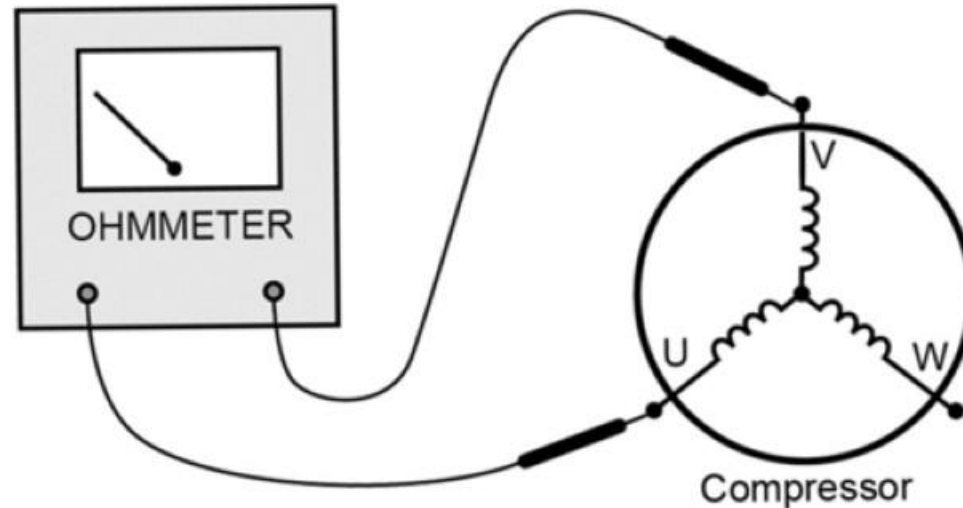



## Testing insulation resistance with megohmmeter

- If the system displays an error code that requires checking the compressor, an insulation resistance test should be completed.
- Remove the leads from the compressor terminals and check the insulation resistance.
- Check between the compressor terminals and the unpainted refrigerant piping.
- If the insulation resistance of the compressor is less than 100k ohms, replace the compressor.



# 3 Phase Fan Motor



- The first step is to measure voltage being supplied by the inverter board at plug X108A (large chassis) X200A (small chassis).
  - Set meter to AC volts.
  - Set the controls to cool mode and adjust the set point temperature until the outdoor unit begins operation.
  - Ground the black meter lead and check all three terminals for AC voltage.
  - If voltage is present, proceed to motor winding check.

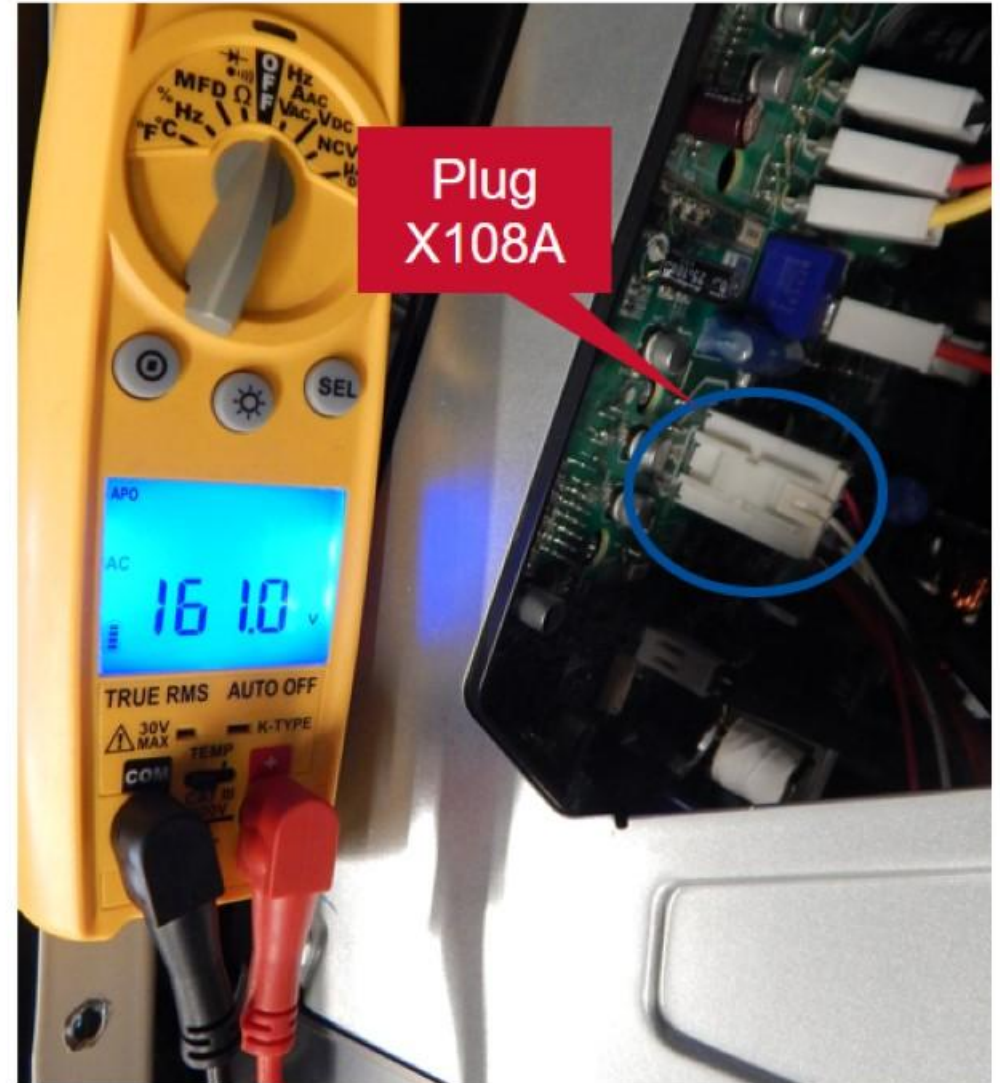

# 3 Phase Fan Motor



## Motor winding check

- Remove fan plug from the inverter board.
- Set meter to ohms.
- Measure the resistance between terminals 1-2, 1-3 and 2-3.
  - Terminal 1-Black
  - Terminal 2-White
  - Terminal 3- Red
- Resistance should be equal between all windings  $\pm 10\%$ .

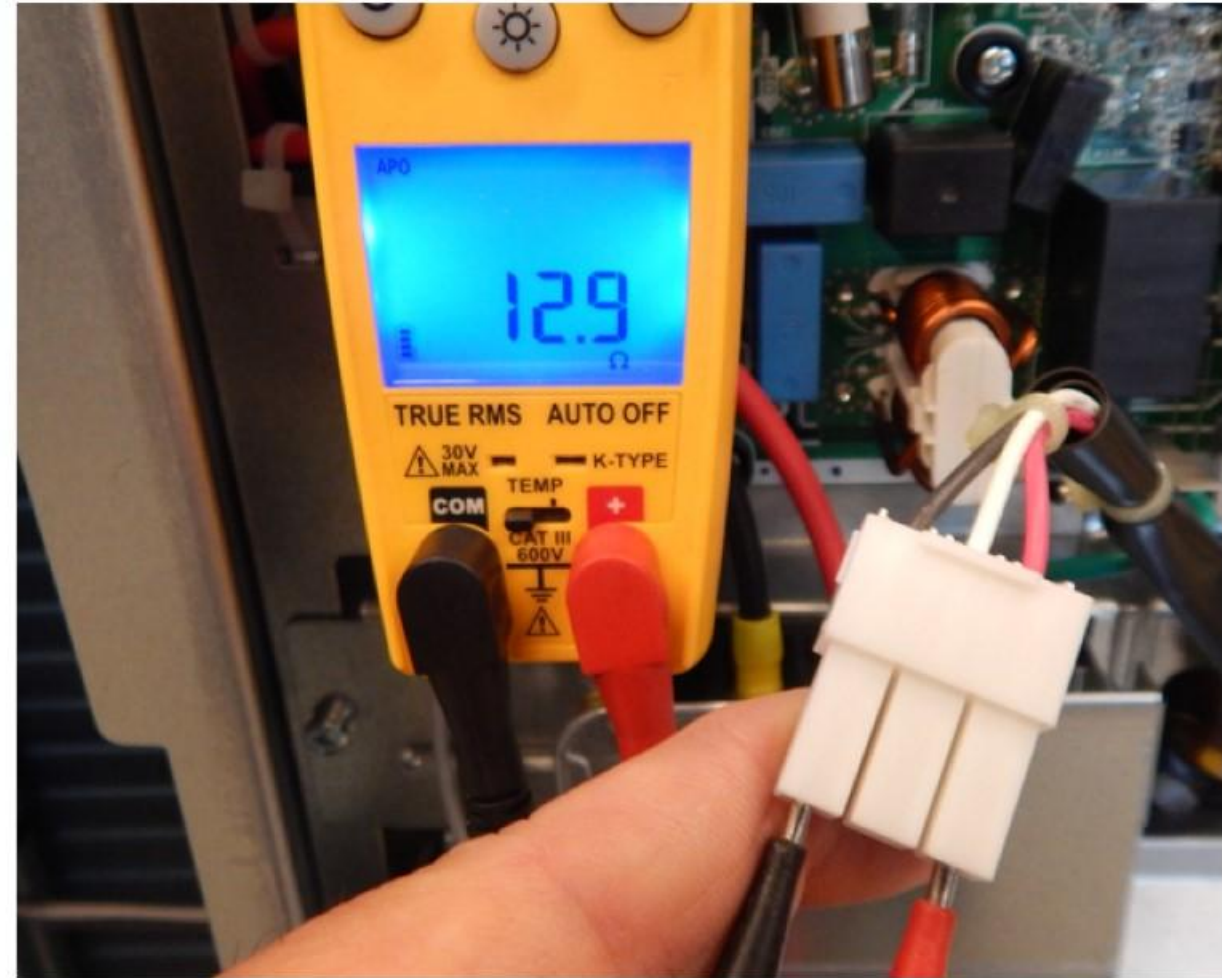

# Thermistors

## Tool recommendation for troubleshooting thermistors and EEVs

- Some of the components to be tested will have a tight space for measuring resistance.
- It is recommended that a pair of extended Molex probe tips be purchased for test leads.
- Most test-meter manufacturers offer this as an accessory for their meters.
- These Molex probes can also be purchased from any local HVAC supply store.



- X900A
  - R2T- Discharge
  - R3T- Liquid line
  - R6T- Suction line
- X901A
  - R4T- Defrost (heat pump)
  - R5T- Outdoor coil
- X902A
  - R1T- Ambient



Plug X901A

Plug X902A

Plug X900A

# Thermistors

## Testing temperature thermistors

- Disconnect power to the outdoor unit.
  - Allow 15 minutes for capacitors to discharge. Verify by checking board.
- Disconnect the thermistor plug from the inverter board.
- Set meter to ohms and read across the two wires from the thermistor to be tested.
  - The ohm meter should read the resistance shown in the table located in the service manual: Thermistor Resistance and Temperature Characteristics.

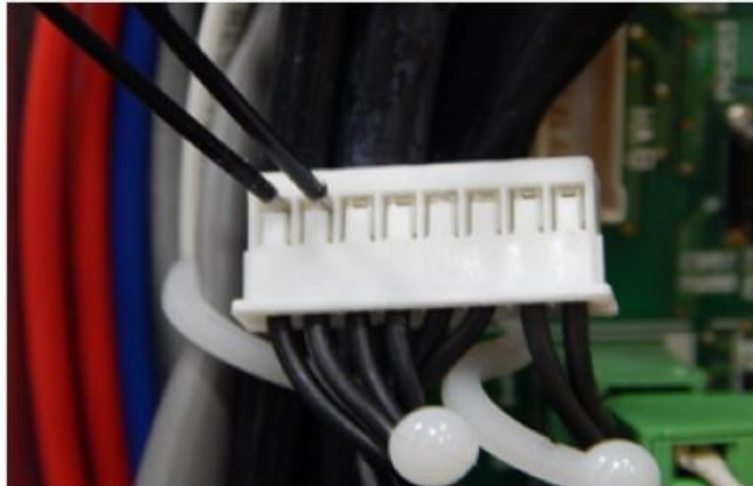

# Thermistors

## Example

- Test resistance for the Ta: Outdoor temperature thermistor.
- Review the appropriate chart in the manual for the proper resistance that should be measured.
- For a 95°F day, the resistance reading for the Ta: Outdoor air thermistor should be 13.07 ohms.

## Thermistor Resistance and Temperature Characteristics

Temp (°C)	Temp (F)	Tm: Coil Tb: Defrost Tl: Liquid Ts: Suction Tgi: Indoor Gas Tli: Indoor Liquid		Td: Discharge		Ta: Outdoor air	
		Thermistor Resistance R (kΩ)	Volts DC (V)	Thermistor Resistance R(kΩ)	Volts DC (V)	Thermistor Resistance R (kΩ)	Volts DC (V)
-30	-22	364.43	4.58	4759.15	4.96	362.48	4.58
-25	-13	267	4.45	3454.24	4.94	265.99	4.45
-20	-4	197.81	4.29	2533.62	4.92	197.31	4.28
-15	5	148.1	4.09	1877.01	4.9	147.86	4.09
-10	14	111.99	3.86	1403.82	4.86	111.88	3.86
-5	23	85.49	3.61	1059.45	4.82	85.43	3.61
0	32	65.84	3.33	806.47	4.77	65.8	3.33
5	41	51.09	3.04	618.95	4.7	51.1	3.04
10	50	39.96	2.74	478.76	4.62	39.99	2.74
15	59	31.5	2.44	373.11	4.53	31.54	2.44
20	68	25.01	2.16	292.86	4.41	25.06	2.16
25	77	20	1.89	231.44	4.28	20.04	1.89
30	86	16.1	1.64	184.11	4.13	16.13	1.64
35	95	13.04	1.42	147.37	3.95	13.07	1.42
40	104	10.63	1.22	118.68	3.76	10.65	1.22
45	113	8.71	1.04	96.13	3.56	8.73	1.05
50	122	7.18	0.89	78.29	3.34	7.18	0.89
55	131	5.95	0.76	64.1	3.11	-	-
60	140	4.96	0.65	52.76	2.87	-	-

# Pressure Sensor

- The Hi/Low Pressure Sensor senses the pressure in the suction line.
- This sensor is attached to plug X17A on large chassis models, and X840A on small chassis models.
- The plug has 3 colored wires installed in pins 1, 3, and 4.

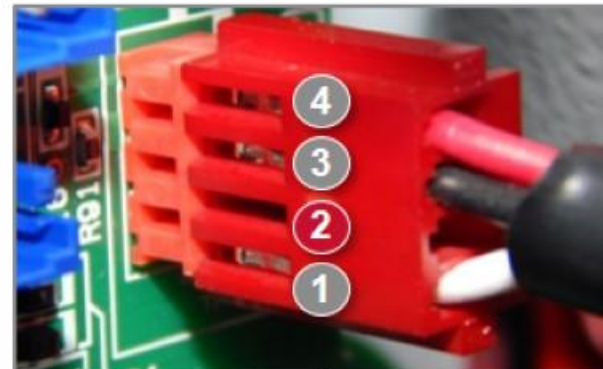
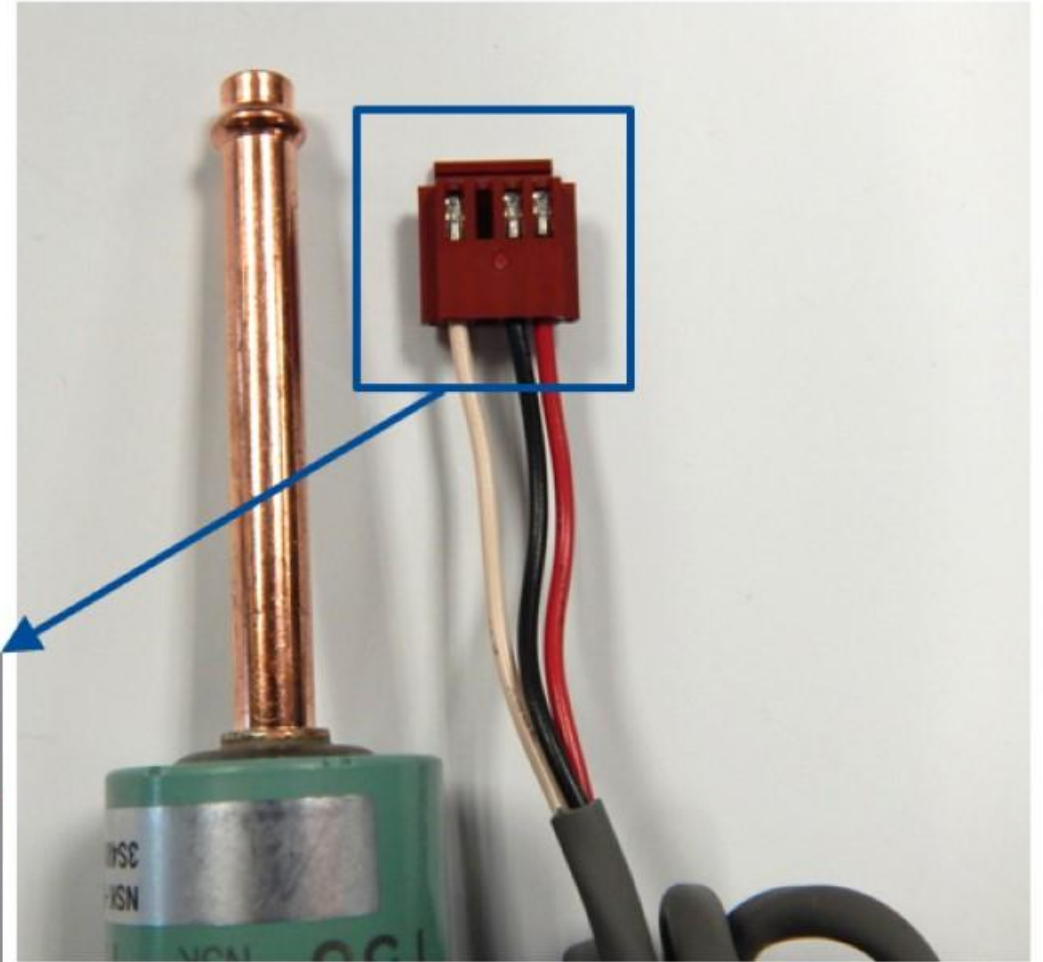

Pin 1: White  
Pin 2: **Empty**

Pin 3: Black  
Pin 4: Red

# Pressure Sensor

## Pin 1

The **white wire** is the signal voltage being fed from the sensor back to the board.

## Pin 2

*Empty*

## Pin 3

The **black wire** is the ground wire.

## Pin 4

The **red wire** is the DC voltage that powers this sensor.

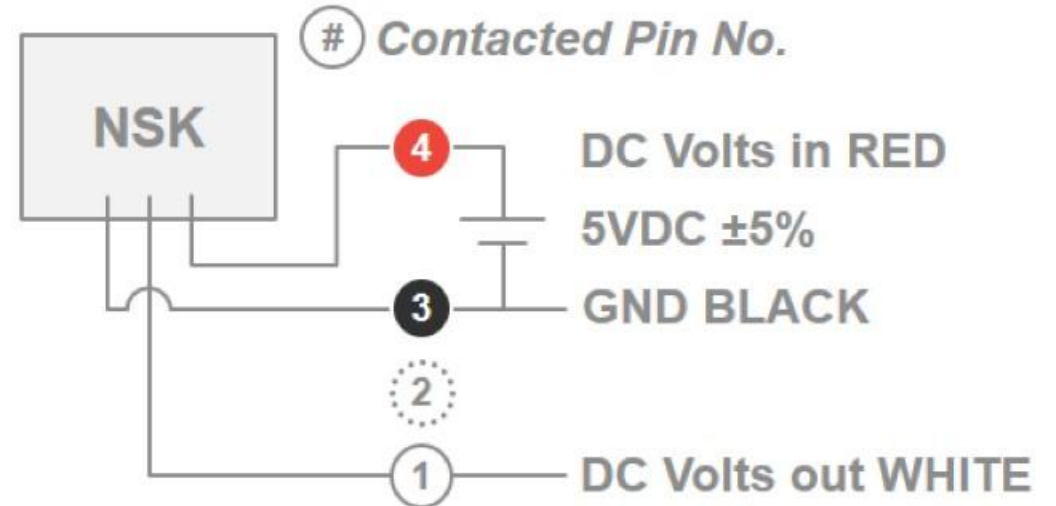
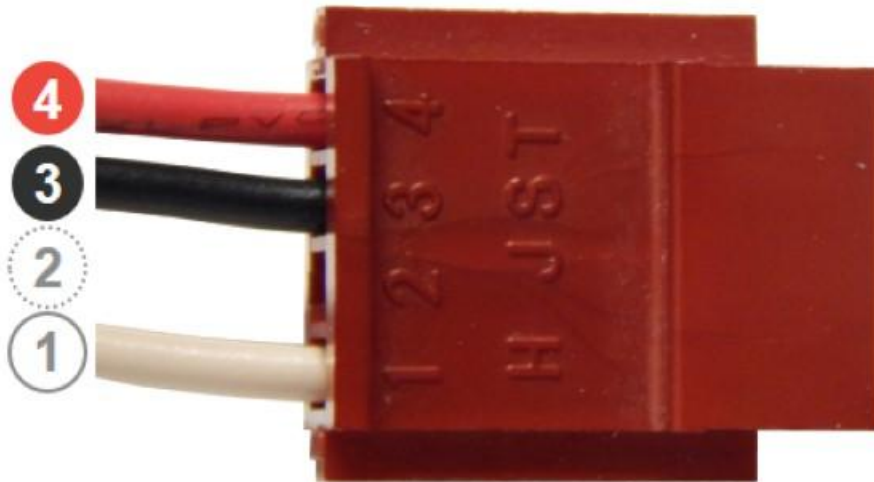

# Pressure Sensor

## Troubleshooting steps

- Once this expected reading is known, set meter to DC volts and measure the sensor output voltage at pins 1 and 3 (black and white).
- If the sensor output voltage does not match or come close to the voltage reading on the chart, replace the sensor.

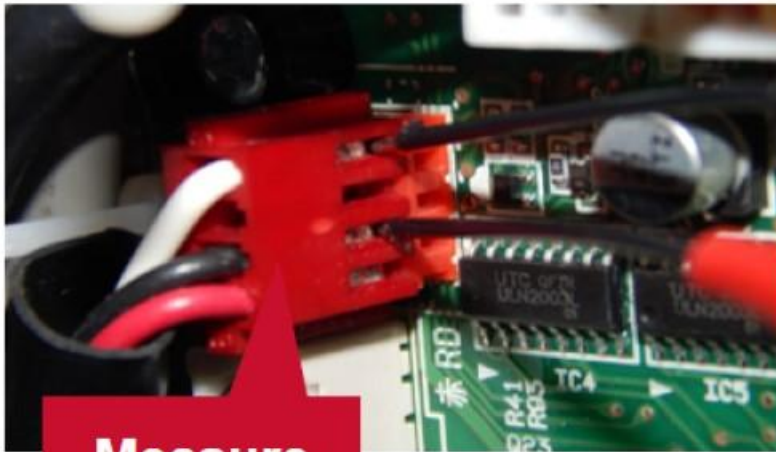

**Measure  
Sensor  
Output**



**Incorrect  
Sensor  
Output**

# Pressure Sensor

## Troubleshooting steps

**Step 1:** Measure the suction and discharge pressure with no call from the thermostat.

- Pressure should be measured on the suction service valve.

**Step 2:** Find this number on the left side of the chart labeled “Detected Pressure PSIG”

- Follow your pressure line horizontally to the right until it hits the diagonal line.
- The chart is used to verify the correct operation of the pressure sensor.
- Once you hit the diagonal line traveling horizontally, drop straight down to read the expected output/signal voltage that should be seen from the sensor back to the board.

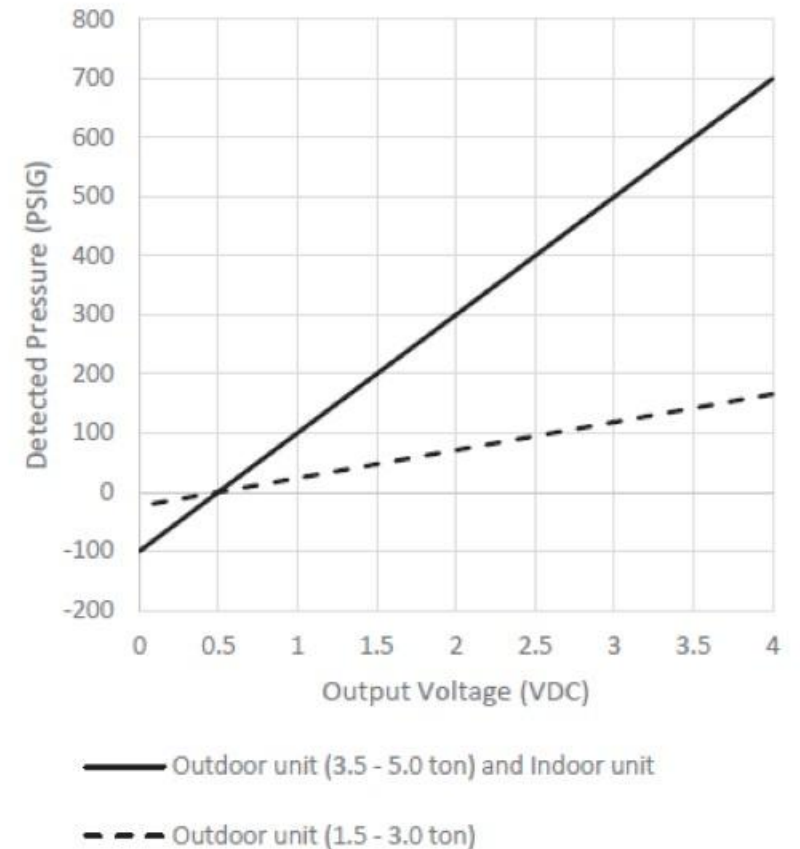

# Electronic Expansion Valve

- Electronic Expansion Valves (EEV) are utilized in the CAPE/ CHPE indoor coils (IDC), AHVE (Air handler) and the ASZS (Outdoor unit).
- To check the resistance of the EEV coil, first disconnect power to the unit.
- Remove EEV Molex connector from the board and measure resistance between the different colored connector pins.
- Resistance readings should fall within the range listed in the service manual test procedures.

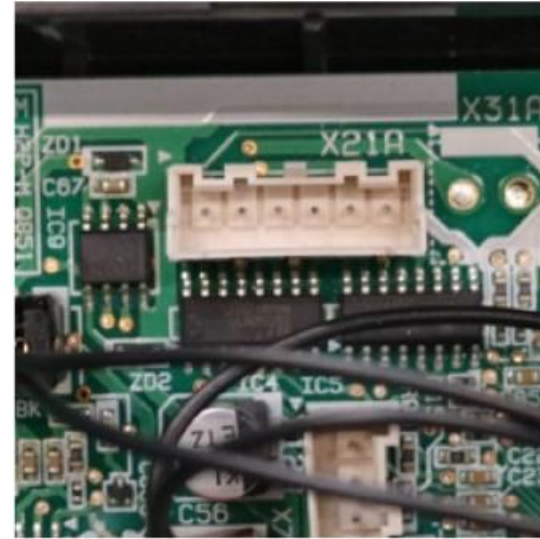



- Set meter to ohms, and measure resistance between all pins to common. (gray)

## Small Chassis EEVs

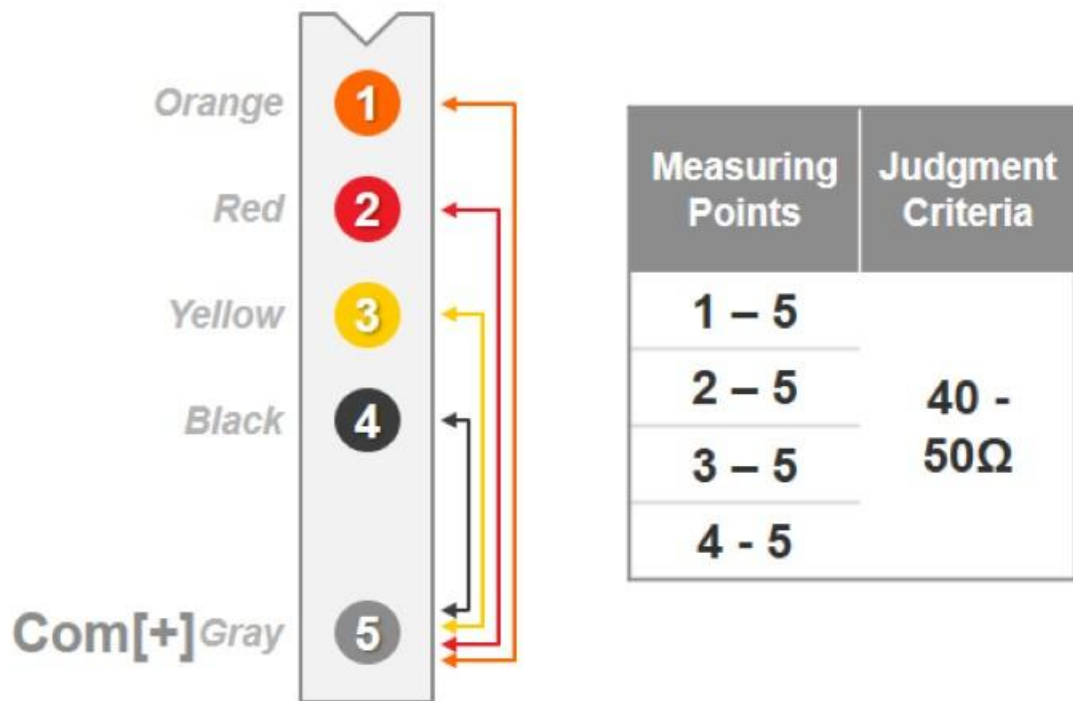

## Large Chassis Coil & Indoor EEVs

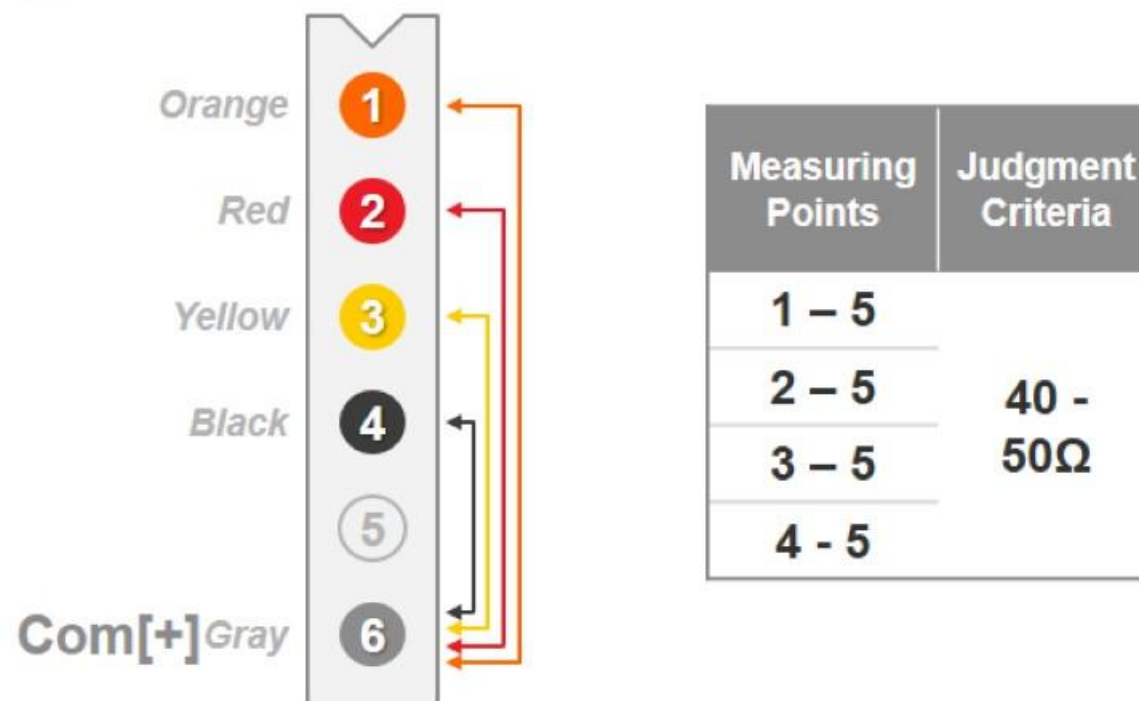

# Reversing Valve Coil



- The reversing valve in the ASZS models have a 208/230 VAC coil.
- The reversing valve coil (RVC) is energized in the cooling mode.
- If there is no manifold gauge movement in cooling mode, check for 208/230 VAC.

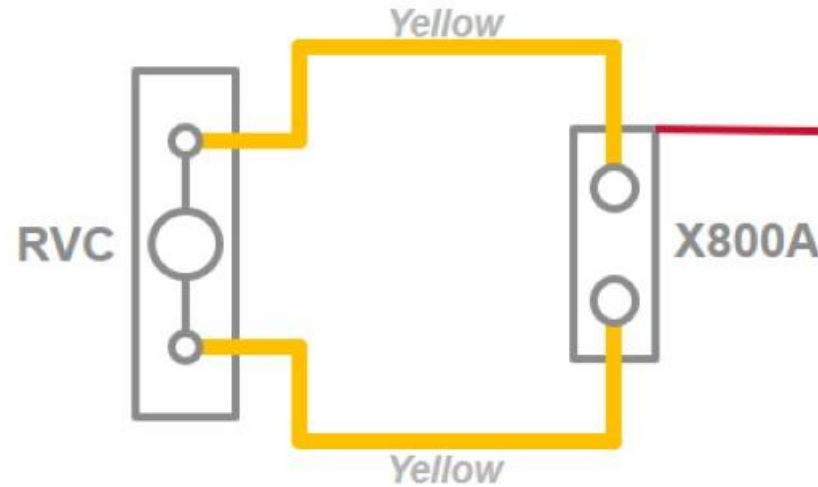

# Reversing Valve Coil

## Troubleshooting steps

- To gain access to the coil and wiring, remove the access door and front panel.
- If 208/230 VAC is present at the plug during cooling operation, inspect the wiring from the plug down to the reversing valve coil.
- If there is no 208/230 VAC at the plug, troubleshoot power being supplied by inverter PCB (may be a board issue).

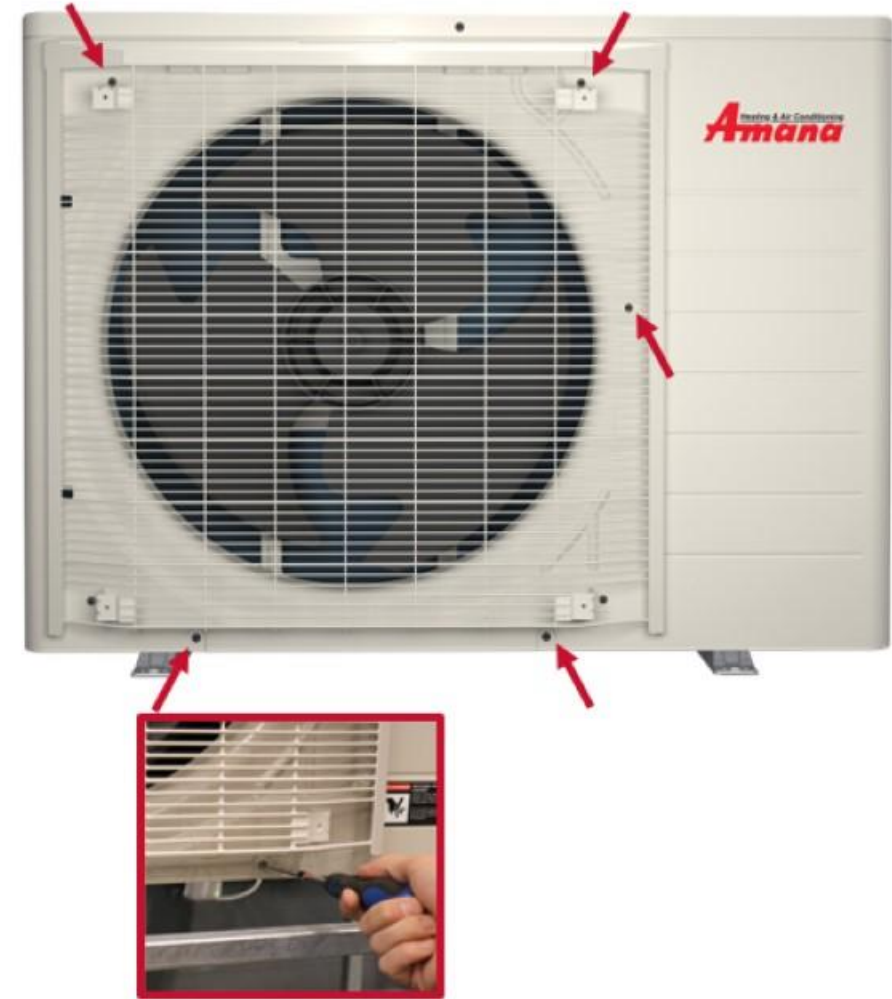



## Troubleshooting steps

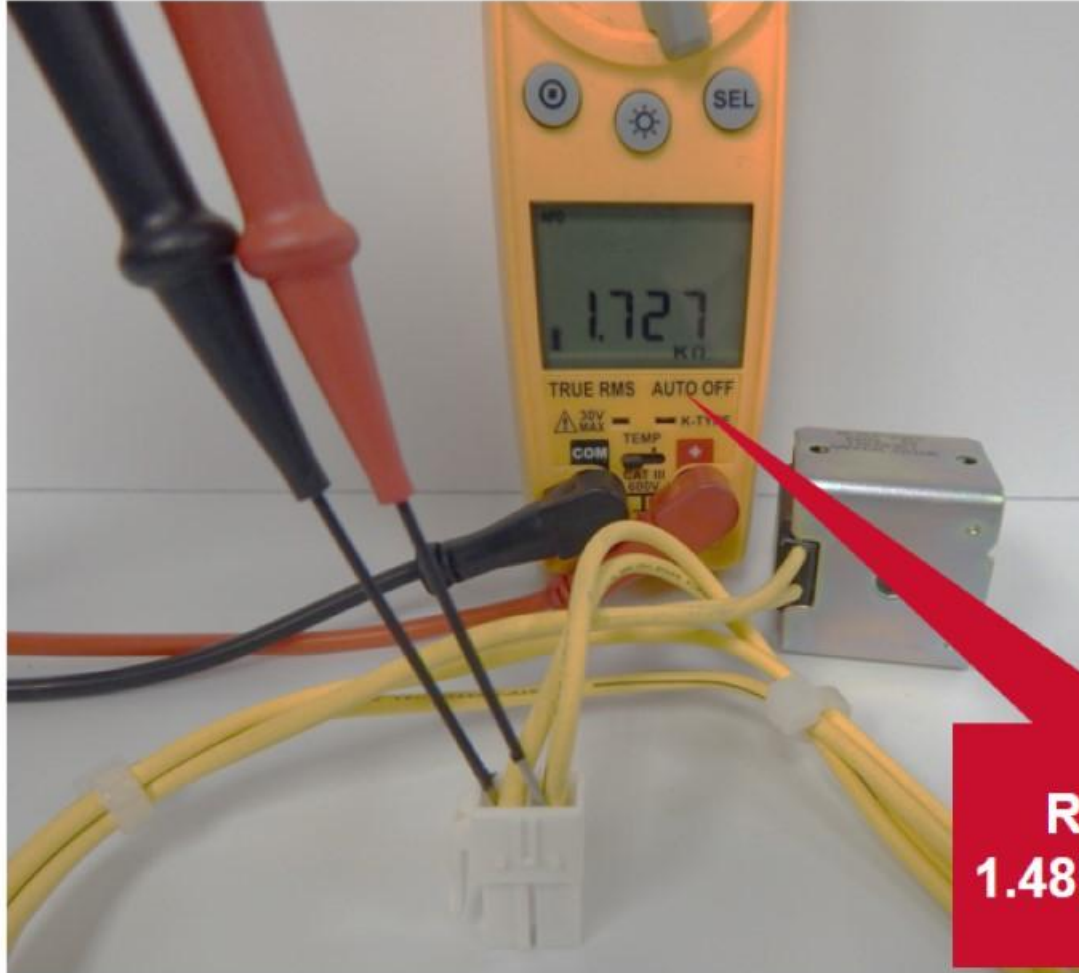

**Resistance:  
1.48k-1.82k ohms**

- If 208/230 VAC is being sent to the coil during cooling operation, it should energize the reversing valve.
- If it doesn't energize it should be removed and tested.
  - Remove plug from the PCB.
  - Set meter to ohms and test coil.
  - Resistance should read between 1.48k-1.82k ohms.

## Agenda

System Status

Inverter Board and Components

Troubleshooting

Replacing Inverter Board

Emergency Modes

D-Checker

# Moving the Cooling Loop & Removing the Printed Circuit Board



The cooling loop attached to the inverter board must be uncovered and moved before removal.

- Disconnect wiring and connectors and remove inverter board assembly.
- Remove the screws from the cooling loop cover that allow it to hinge open.
- Pull back gently on the 3/8" copper tubing, and carefully slide the PCB from behind the cooling loop.
- Wipe all old/stale grease from the cooling loop.



# Replacing Inverter Board

## Thermal grease application

- Thermal grease applied between the heat sink and the refrigerant cooling loop allows for proper cooling of PCB circuits. (IGBTs)
- Failure to replace the grease on cooling loop or could damage the board.
- ONLY use Daikin approved 9S00859, thermal grease.

# 9S00859

## THERMAL GREASE

# Replacing Inverter Board

Thermal grease replacement: refer to service manual for instructions.

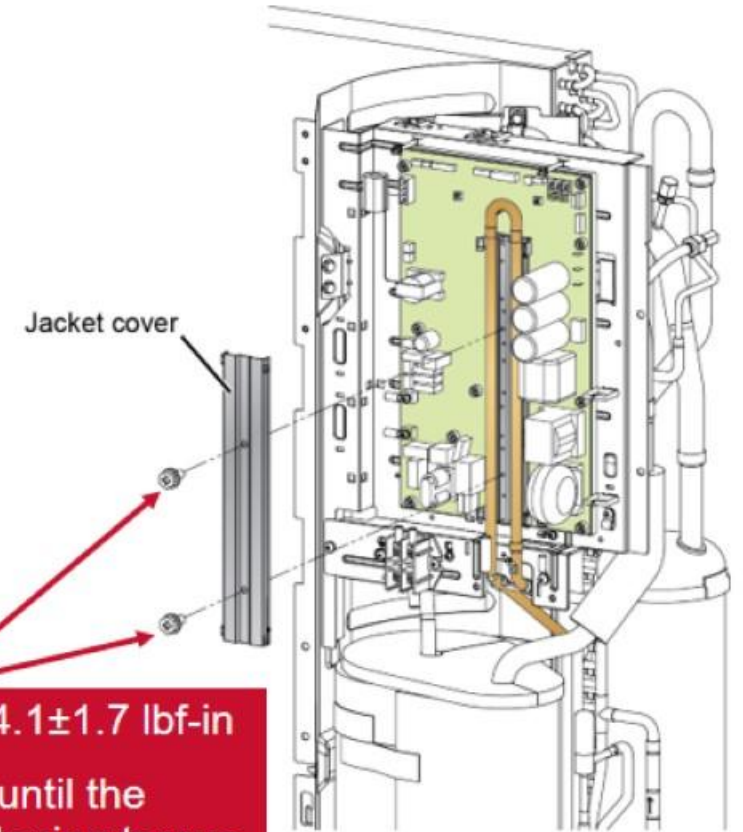
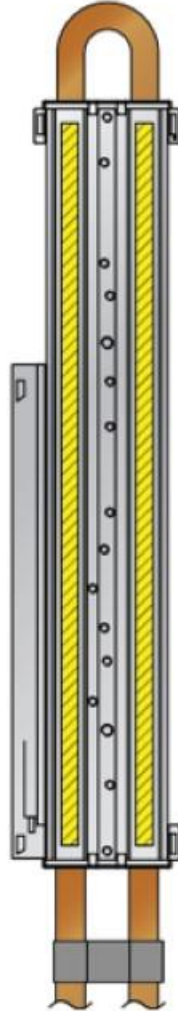
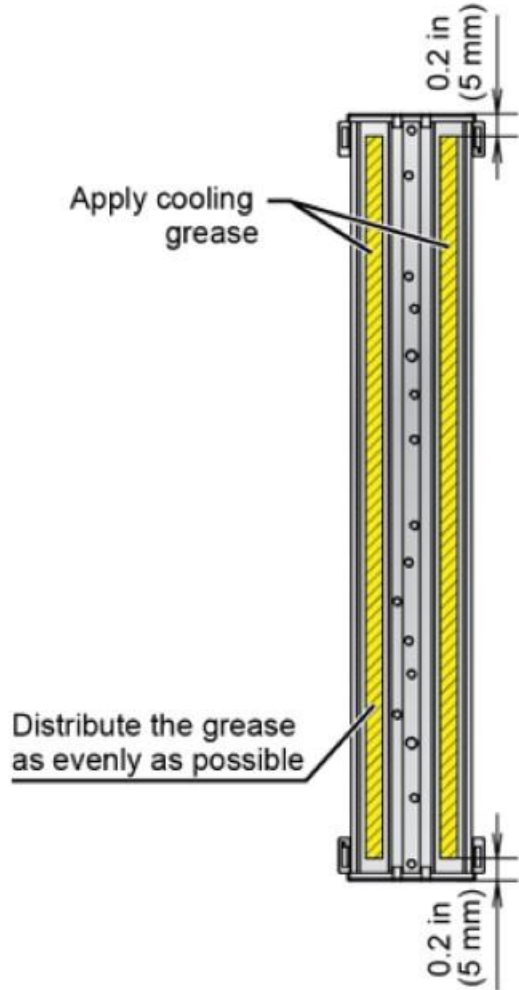

**Tightening Torque:  $14.1 \pm 1.7$  lbf-in**  
Tighten with a driver until the position where a tightening torque increases suddenly. Then extra-tighten by  $30^\circ - 40^\circ$

## Agenda

System Status

Inverter Board and Components

Troubleshooting

Replacing Inverter Board

**Emergency Modes**

D-Checker

## Agenda

System Status

Inverter Board and Components

Troubleshooting

Replacing Inverter Board

Emergency Modes

**D-Checker**

# D-Checker

Part # 999187T

- The Daikin D-Checker software is used for monitoring and recording operation data of HVAC equipment using a connection cable exclusive to D-Checker.
  - Data/status items that are supported by this software differ from model to model.
- D-Checker transmits operating data from an HVAC system through a PCB connector on the outdoor unit to a mobile device.

**NOTE:** Data monitoring/recording of multiple outdoor units is not supported.



# Connection Procedure

- Be sure to power down the equipment to ensure safety.
- Connect BTSC/i2S to the PCB (X-41A)
  - Large chassis: 5-pin connection harness
  - Small chassis: 7-pin connection harness
- BTSC/i2S will have an LED blinking every 0.5 seconds if operational







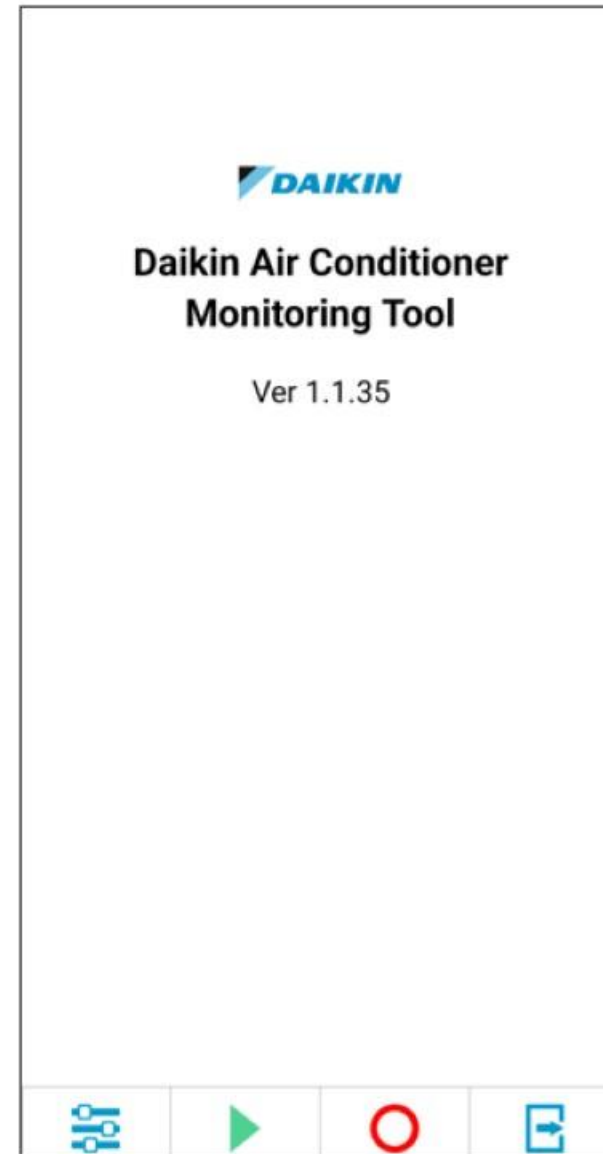
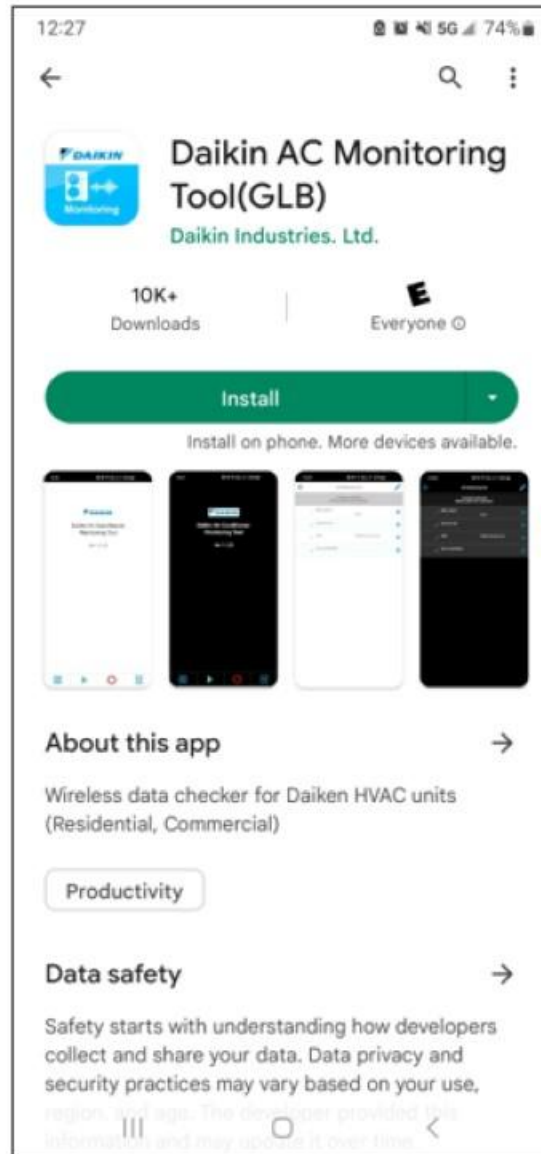











D-Checker port



# Download the Daikin AC Monitoring Tool App



# Main Menu Legend

	Options, settings		Back		Edit data		Connect (protocol check)	
	To playback mode			Cancel		Select all data		Stop recording
	To record mode, start recording		OK		Send selected data			
	Exit app		Show graph (play mode only)		Delete selected data			
	To main menu		Change view (tab/one page)		Scan Bluetooth devices			

Icons

# App Common Settings (Options)

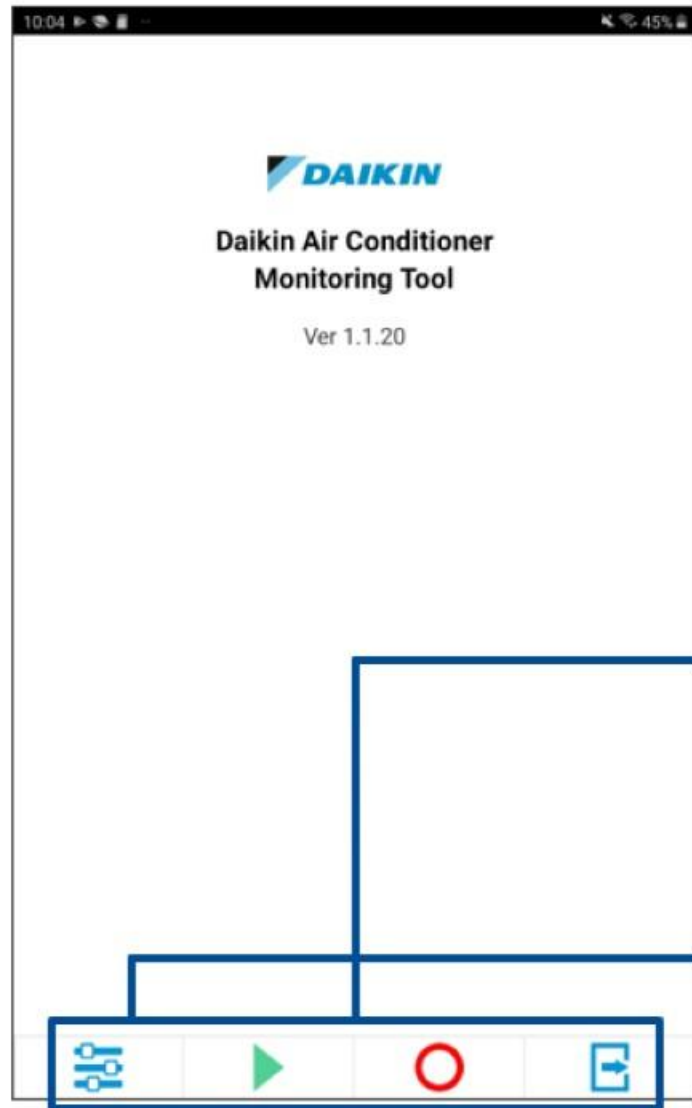

All menus will be available after service office and responsible person entered

“Options” button

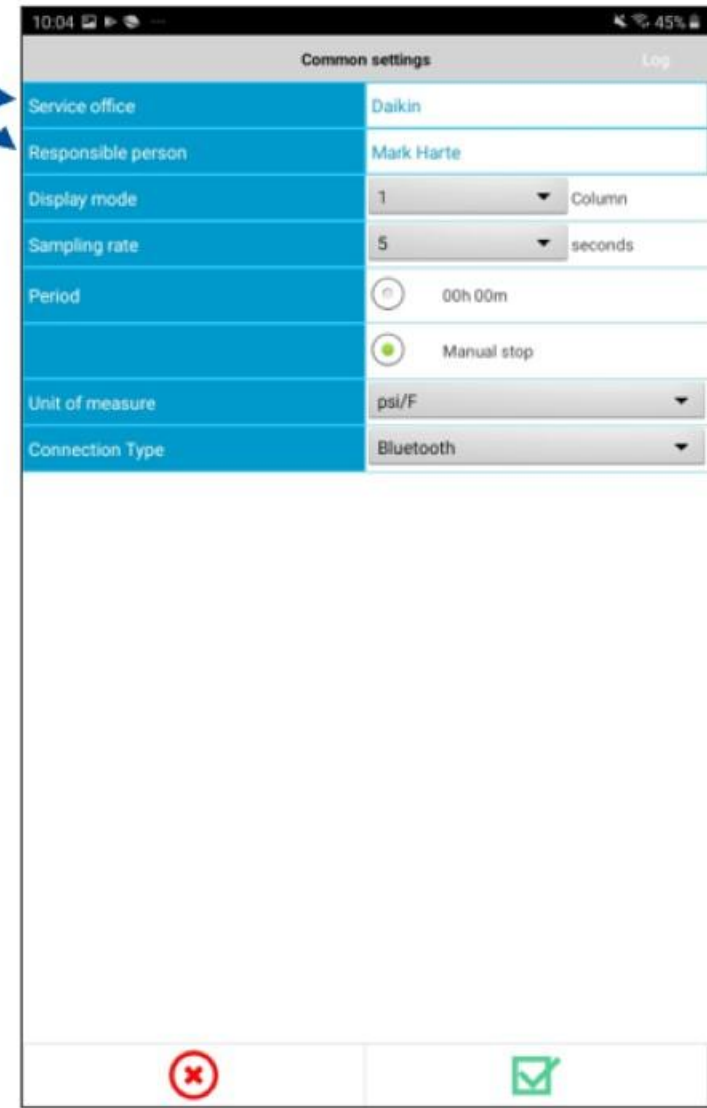

# Pairing the Bluetooth D-checker

- Open device Bluetooth setting and locate BTSC to pair.
- Selecting BTSC in the Bluetooth setting will prompt you to enter the PIN “3131”

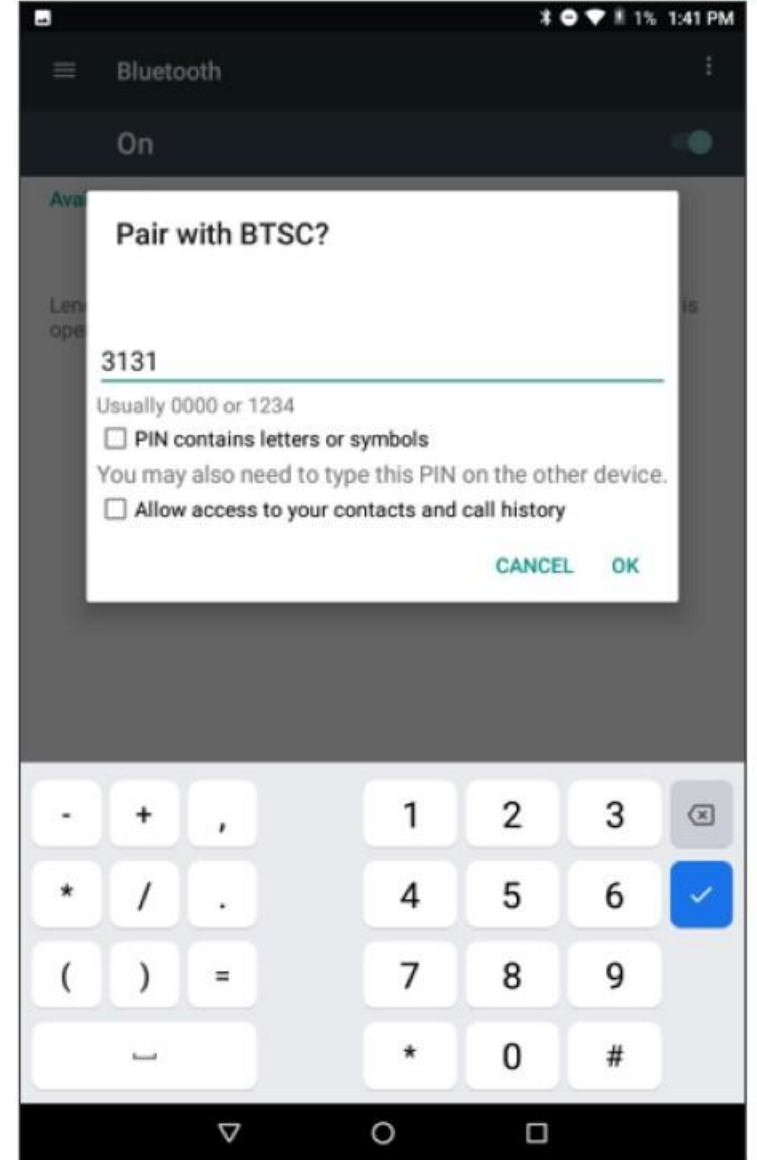
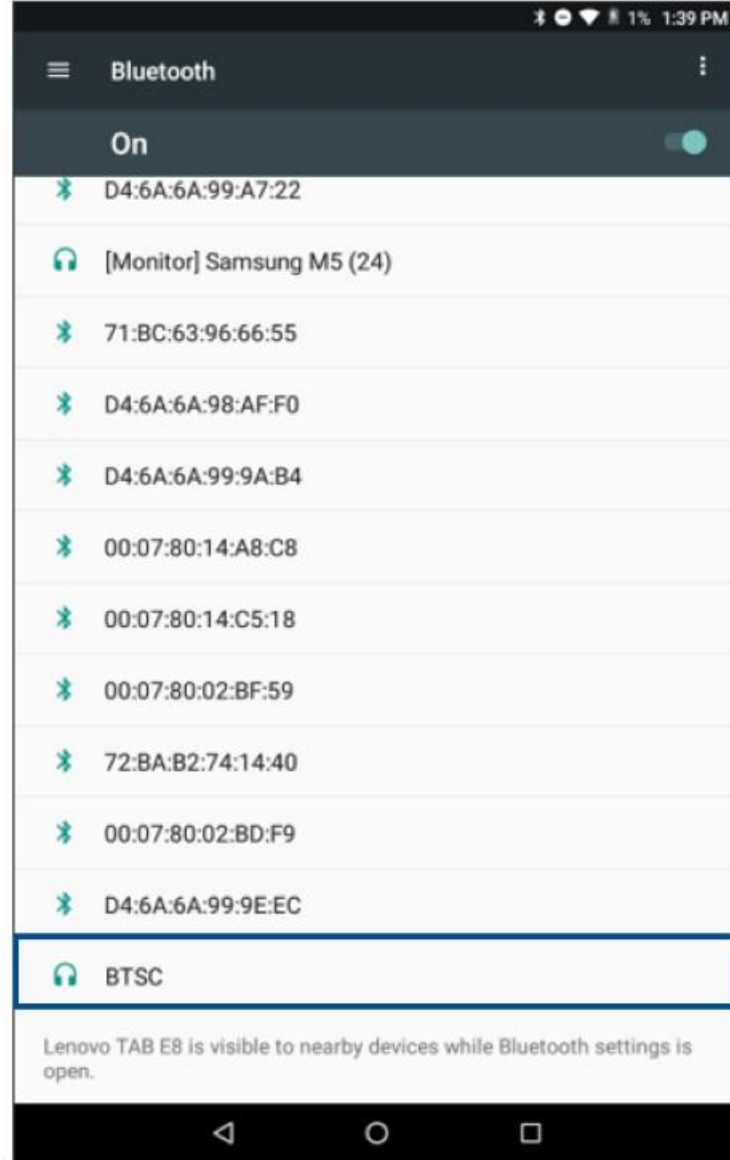

# Pairing the Bluetooth D-checker

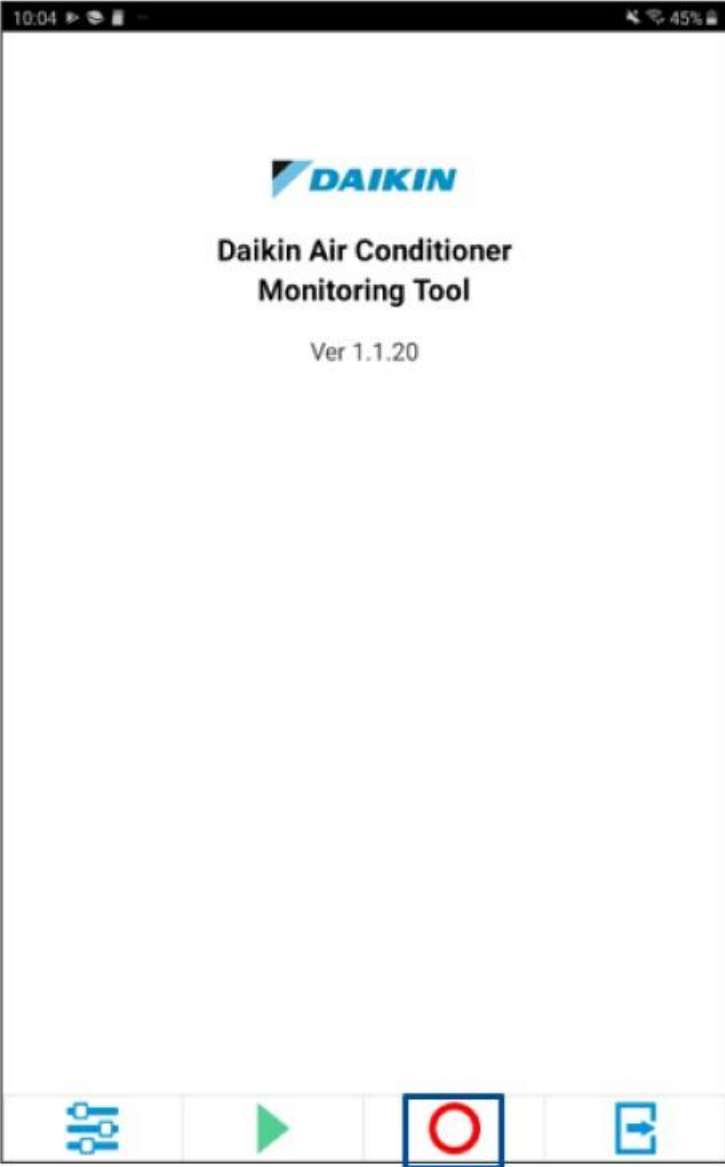

Tap record icon

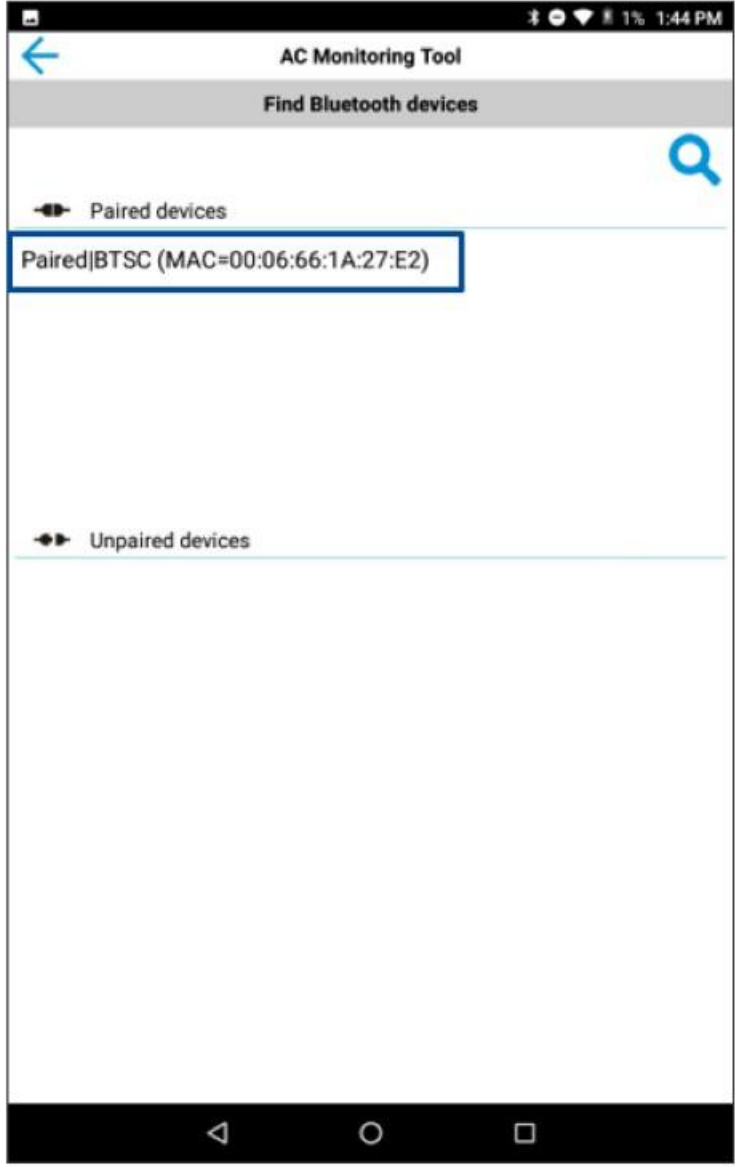

# Pairing the Bluetooth D-checker with the Equipment

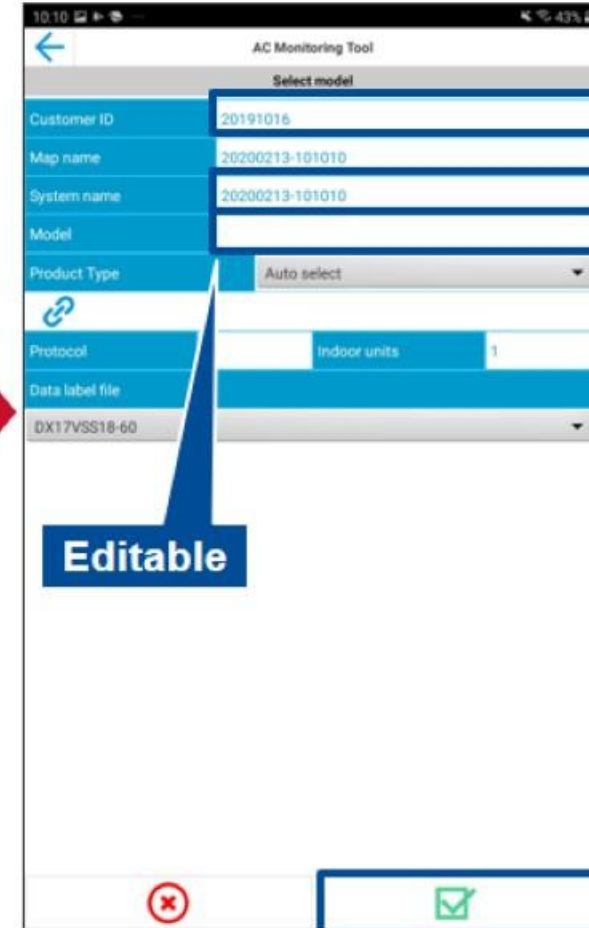
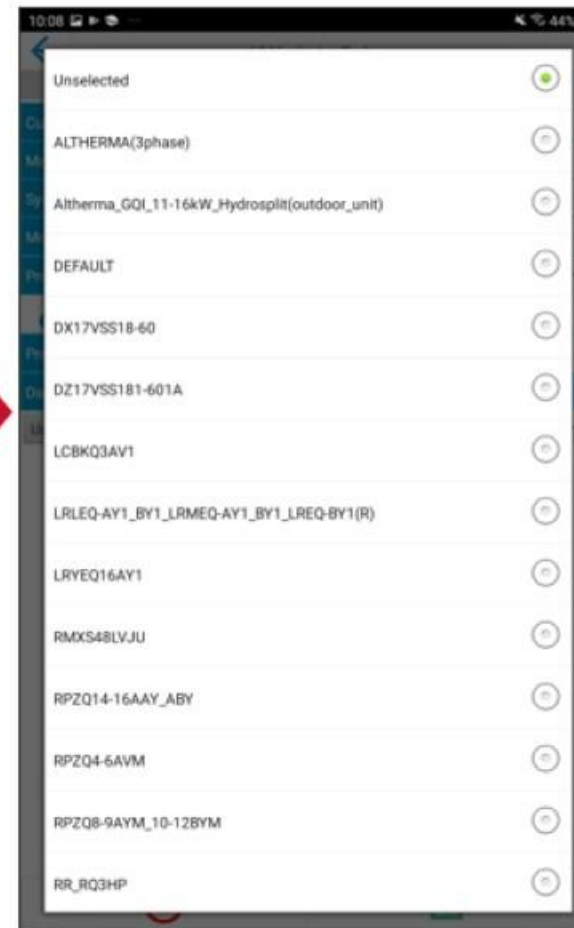
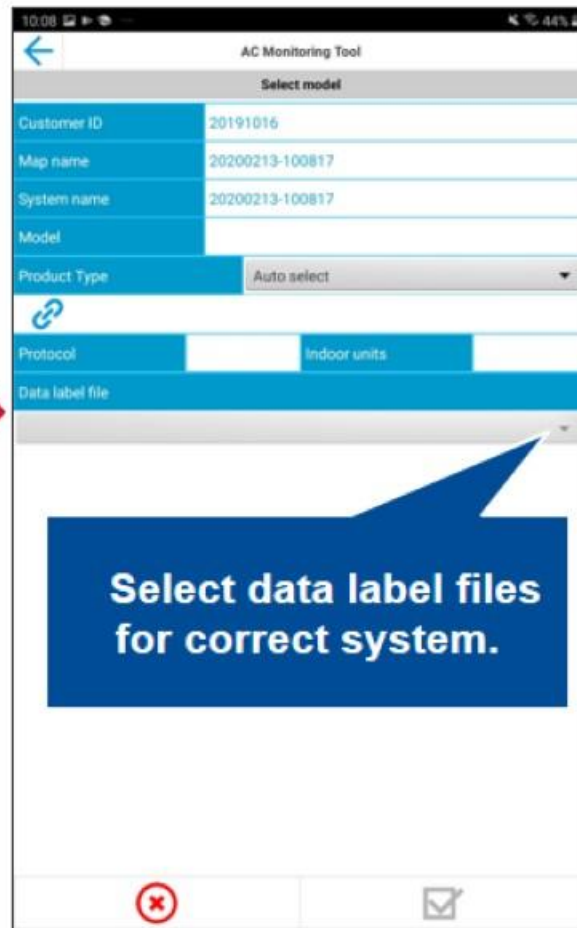

# Viewing Data

10:11 43%

AC Monitoring Tool

20191016 Err:0

00:00:00 Protection:OFF

Basic data Control Sensor Actuator Indoor unit

Operation mode	Cooling
Outdoor temp.	68.0 (F)
Discharge temp.	101.8 (F)
Suction temp.	54.9 (F)
High pressure	226.1 (psi)
Low pressure	112.4 (psi)
INV current	2.4
INV frequency	31

Navigation icons: Home, Settings, Refresh, Stop, Home

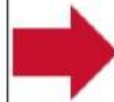

10:13 42%

AC Monitoring Tool

20191016 Err:0

00:01:25 Protection:OFF

Basic data

Operation mode	Cooling	Outdoor temp.	68.0 (F)
Discharge temp.	104.2 (F)	Suction temp.	59.2 (F)
High pressure	226.1 (psi)	Low pressure	113.8 (psi)
INV current	2.4	INV frequency	31

Control

Sensor

Actuator

Indoor unit

Indoor address	0
IDU op. mode[#]	Cooling
Therm. on/off[#]	ON
Error code[#]	00
R/C setpoint[#]	32.0 (F)
IDU air temp. [°]	32.0 (F)
IDU liq. temp. [°]	32.0 (F)
IDU gas temp. [°]	32.0 (F)
IDU EV[psi][°]	132
R/C therm temp[°]	32.0 (F)
Request CFM(x10)	42
Present CFM(x10)	41
Indoor pressure	7.8

Navigation icons: Home, Settings, Refresh, Stop, Home

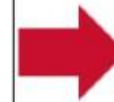

10:13 42%

AC Monitoring Tool

20191016 Err:0

00:01:35 Protection:OFF

Basic data

Operation mode	Cooling	Outdoor temp.	68.2 (F)
Discharge temp.	104.5 (F)	Suction temp.	59.4 (F)
High pressure	226.1 (psi)	Low pressure	113.8 (psi)
INV current	2.4	INV frequency	31

Control

Op mode	Cooling	Therm. on/off	ON
Restart standby	OFF	Startup ctrl	OFF
Defrost op.	OFF	Oil ret op.	OFF
Pres eq. operation	OFF	Demand signal	OFF
Low noise ctrl.	OFF	Freeze protection	OFF
Error type	Normal	Error code	00
Disch temp. drop	OFF	Disch prtc rtry qty	0
INV cur. drop	OFF	INV cur prtc rtry qty	0
HP drop ctrl.	OFF	HP prtc rtry qty	0
LP drop ctrl.	OFF	LP prtc rtry qty	0
Fin temp drop ctr	OFF	Fin tmp prtc rtry qty	0
Retry code	0		

Sensor

Actuator

Indoor unit

Indoor address	0
IDU op. mode[#]	Cooling
Therm. on/off[#]	ON

Navigation icons: Home, Settings, Refresh, Stop, Home

# Settings

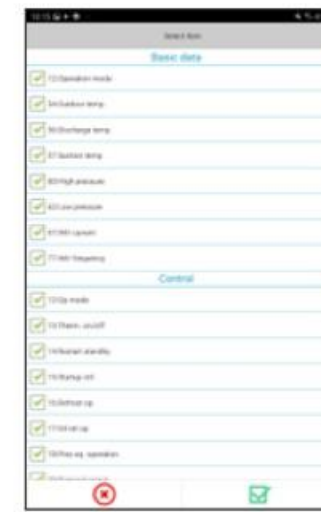
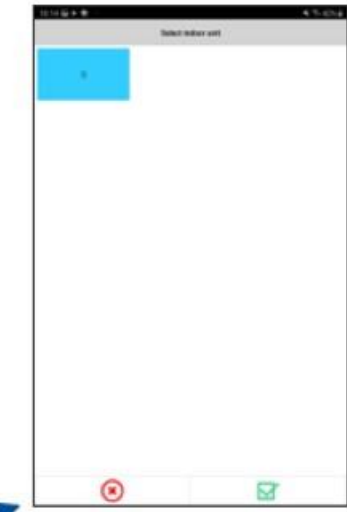
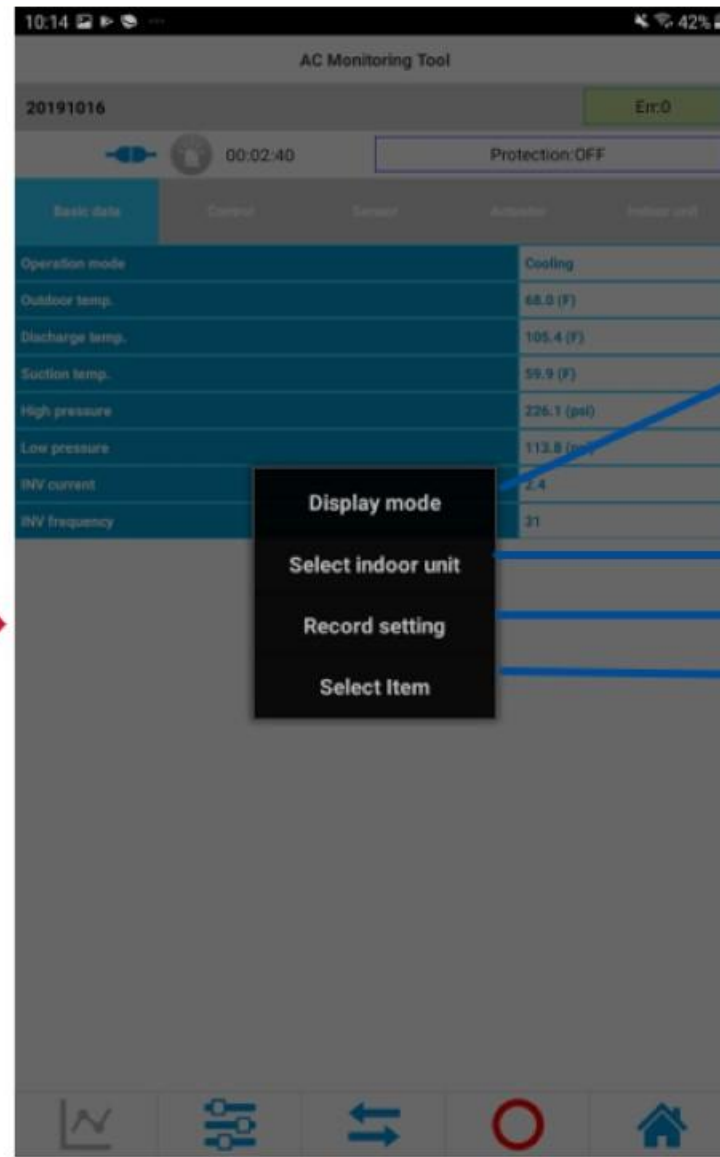
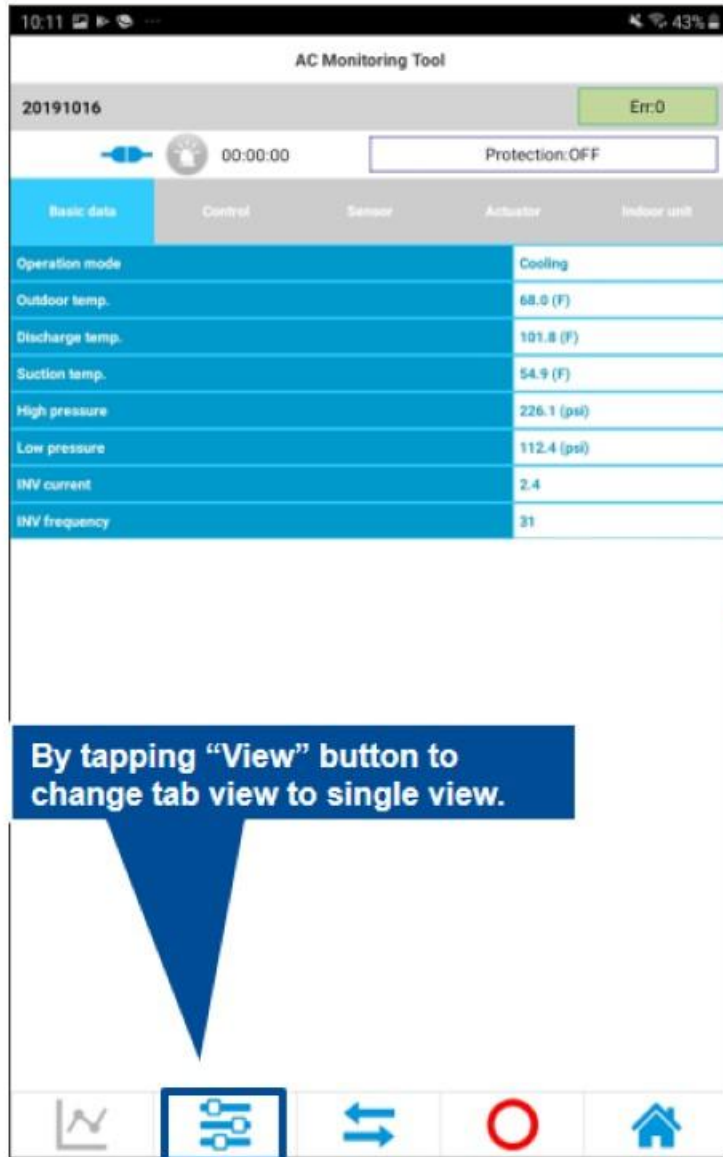

# How To Record Data

10:11 43%  
AC Monitoring Tool  
20191016 Err:0  
00:00:00 Protection:OFF

Basic data	Control	Sensor	Actuator	Indoor unit
Operation mode	Cooling			
Outdoor temp.	68.0 (F)			
Discharge temp.	101.8 (F)			
Suction temp.	54.9 (F)			
High pressure	226.1 (psi)			
Low pressure	112.4 (psi)			
INV current	2.4			
INV frequency	31			



10:11 43%  
AC Monitoring Tool  
20191016 Err:0  
00:00:00 Protection:OFF

Basic data	Control	Sensor	Actuator	Indoor unit
Operation mode	Cooling			
Outdoor temp.	68.0 (F)			
Discharge temp.	102.6 (F)			
Suction temp.	55.4 (F)			
High pressure	226.1 (psi)			
Low pressure	110.9 (psi)			
INV current	2.4			
INV frequency	31			

Start recording. Proceed?  
Sampling rate:5seconds  
Manual stop

Yes No

# How To Record Data

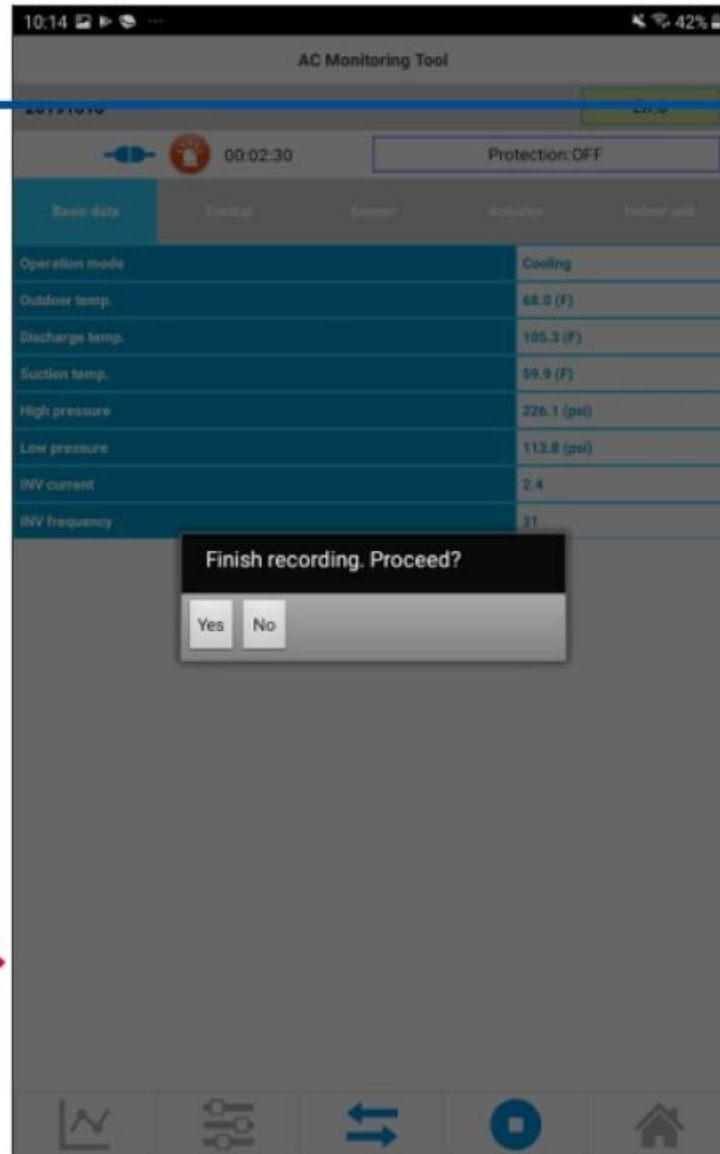

No alarm    In alarm    Error status  
Err:0      Err:U1      Error code

On upper right corner, error status and error code are always indicated. In case of no error, "0" is indicated.

# How To Playback Recorded Data

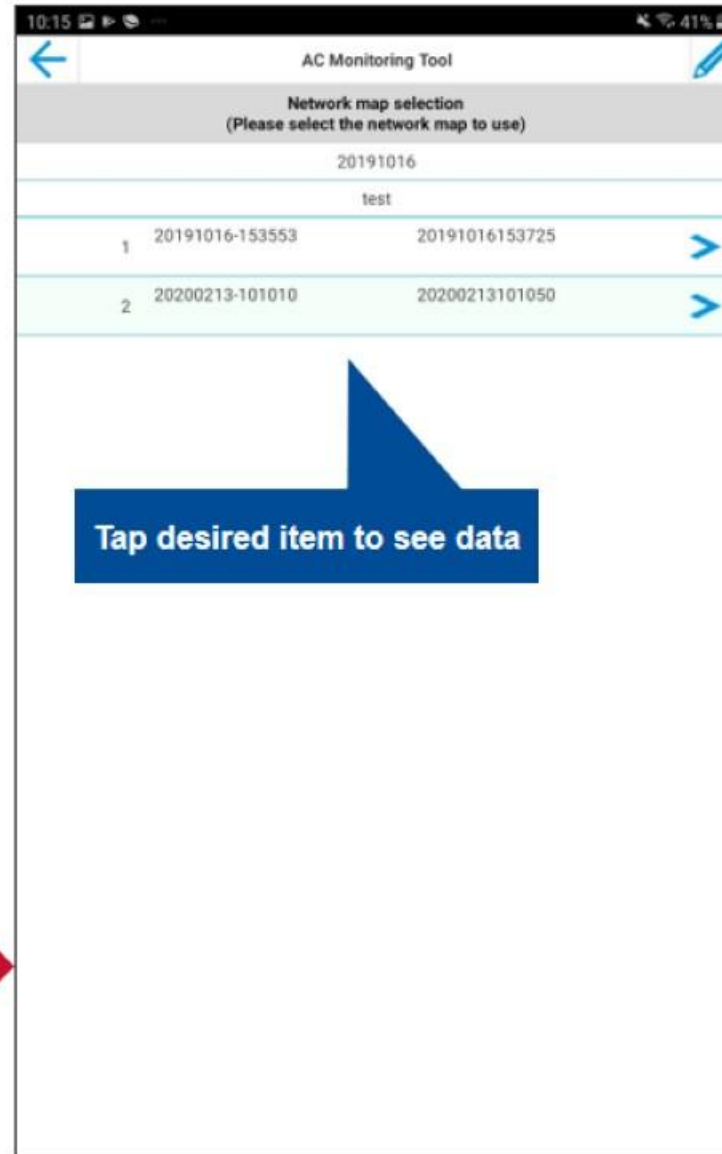
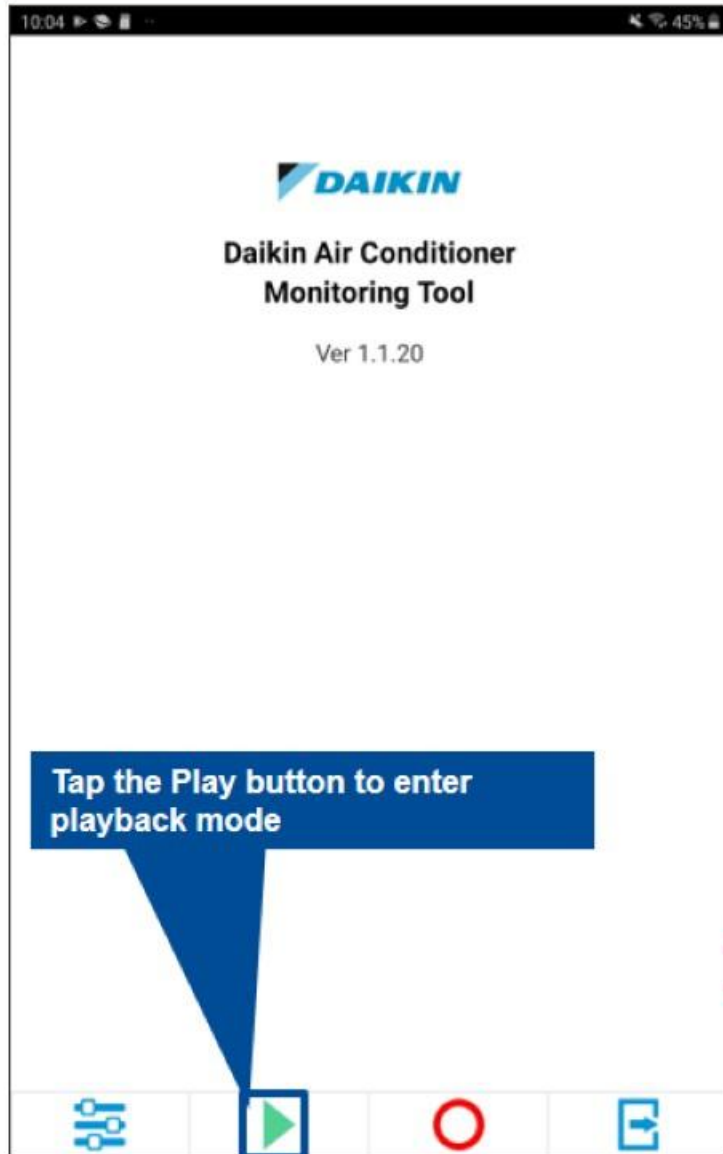

# How To Playback Recorded Data

AC Monitoring Tool

20191016 Err:0

2020-02-13 10:12:00 Protection:OFF

Basic data	Control	Sensor	Actuator	Indoor unit
Indoor address		0		
IDU op. mode[s]		Cooling		
Therm. on/off[s]		ON		
Error code[s]		00		
R/C setpoint[s]		32.0 (F)		
IDU air temp. [s]		32.0 (F)		
IDU liq. temp. [s]		32.0 (F)		
IDU gas temp. [s]		32.0 (F)		
IDU EV(pls)[s]		128		
R/C therm temp[s]		32.0 (F)		
Request CFM(x10)		42		
Present CFM(x10)		41		
Indoor pressure		7.7		

Tap > to proceed to next time slot, tap >> to proceed to the end of record



AC Monitoring Tool

20191016 Err:0

2020-02-13 10:12:30 Protection:OFF

Basic data	Control	Sensor	Actuator	Indoor unit
Comp (rps)			31	
Fan 1 (step)			4	
EV 1 (pls)			480	
4 way valve			OFF	
Crank case heater			OFF	
Y1S			OFF	
Y2S			OFF	
Y3S			OFF	
Comp op command			ON	
Fan1 op command			ON	
Fan2 op command			OFF	
Trgt comp. (rps)			30	
Trgt o_fan1 (rpm)			375	
Trgt o_fan2 (rpm)			0	

# How To Playback Recorded Data



AC Monitoring Tool

20191016 Err:0

2020-02-13 10:12:00 Protection:OFF

Basic data	Control	Sensor	Actuator	Indoor unit
Operation mode	Cooling			
Outdoor temp.	68.0 (F)			
Discharge temp.	102.7 (F)			
Suction temp.	55.9 (F)			
High pressure	226.1 (psi)			
Low pressure	110.9 (psi)			
INV current	2.4			
INV frequency	31			

Tap Graph button to enter graph mode.



AC Monitoring Tool

20191016 Err:0

2020-02-13 10:12:00 Protection:OFF

Analog X-axis Y-axis Legend

Digital

# How To Email Data Recording

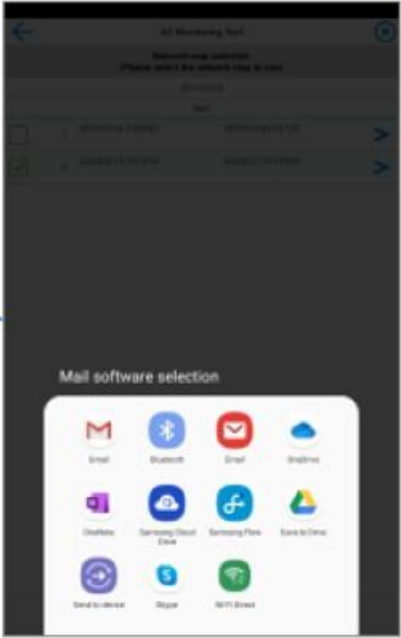
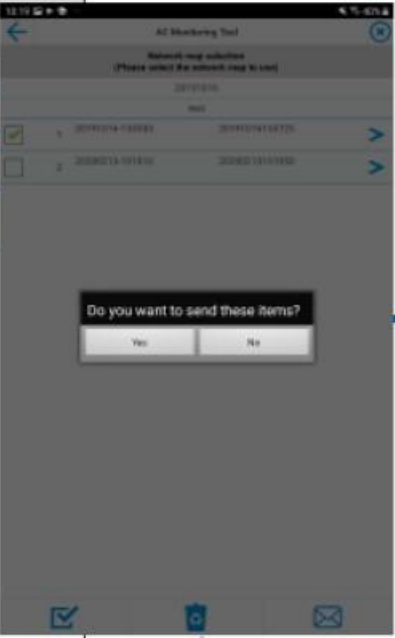
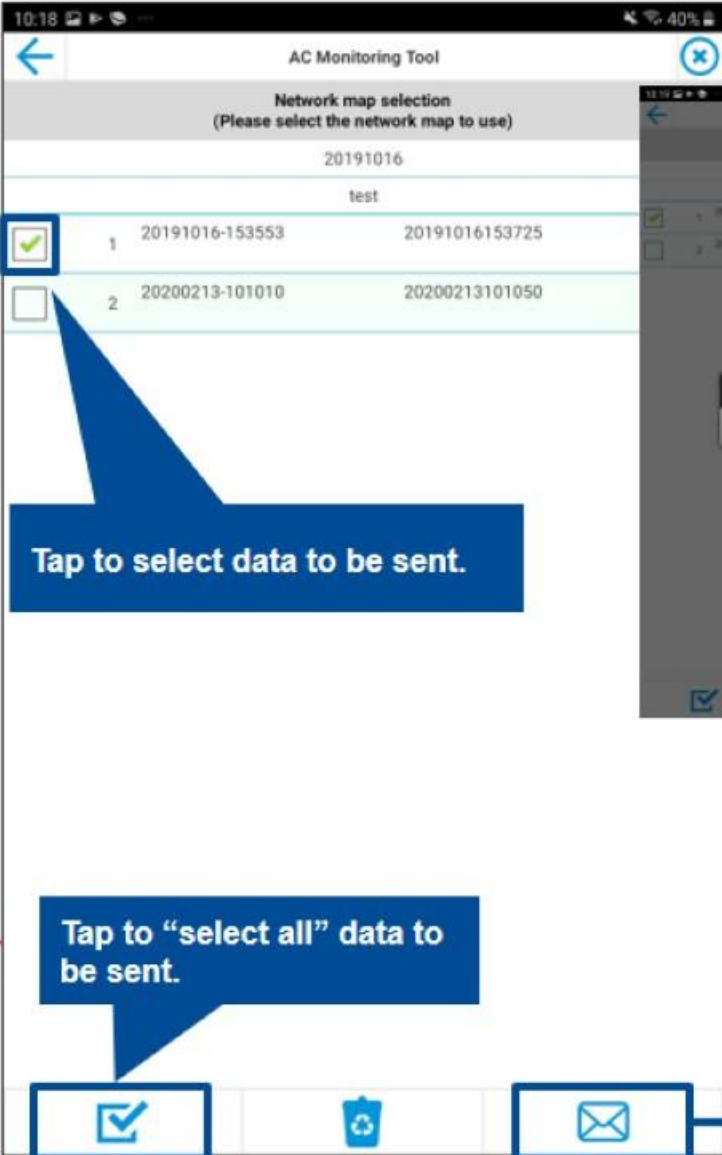
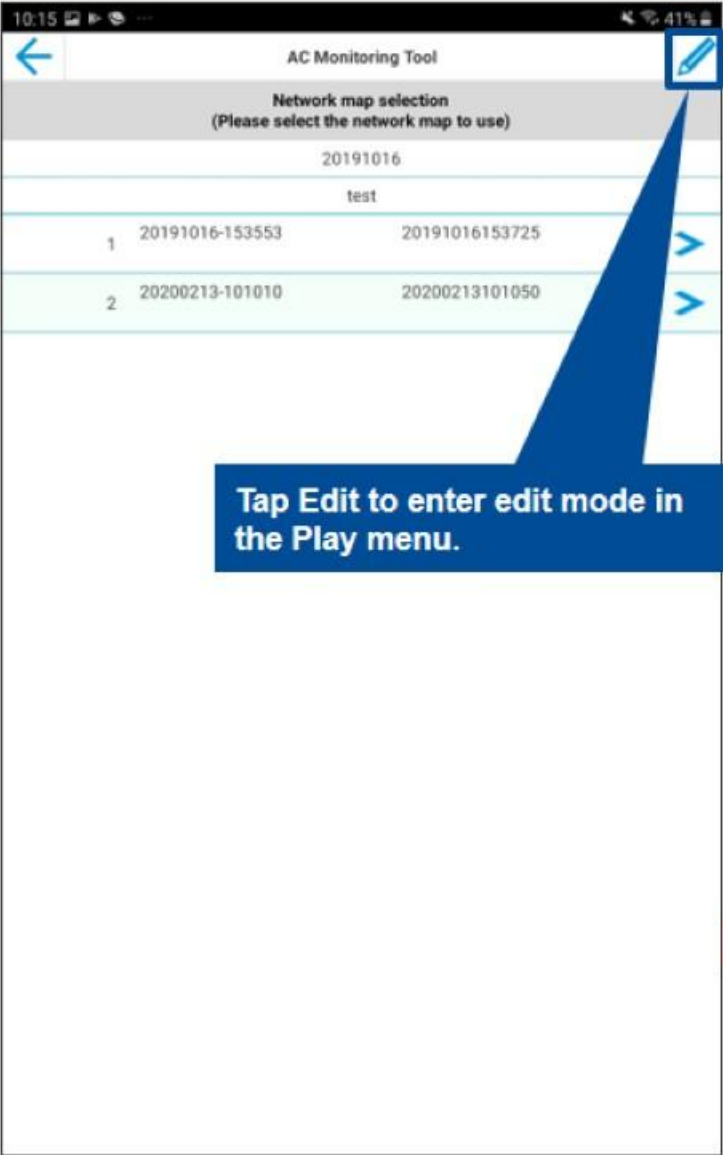

# How To Import Mobile .TGZ File Sent

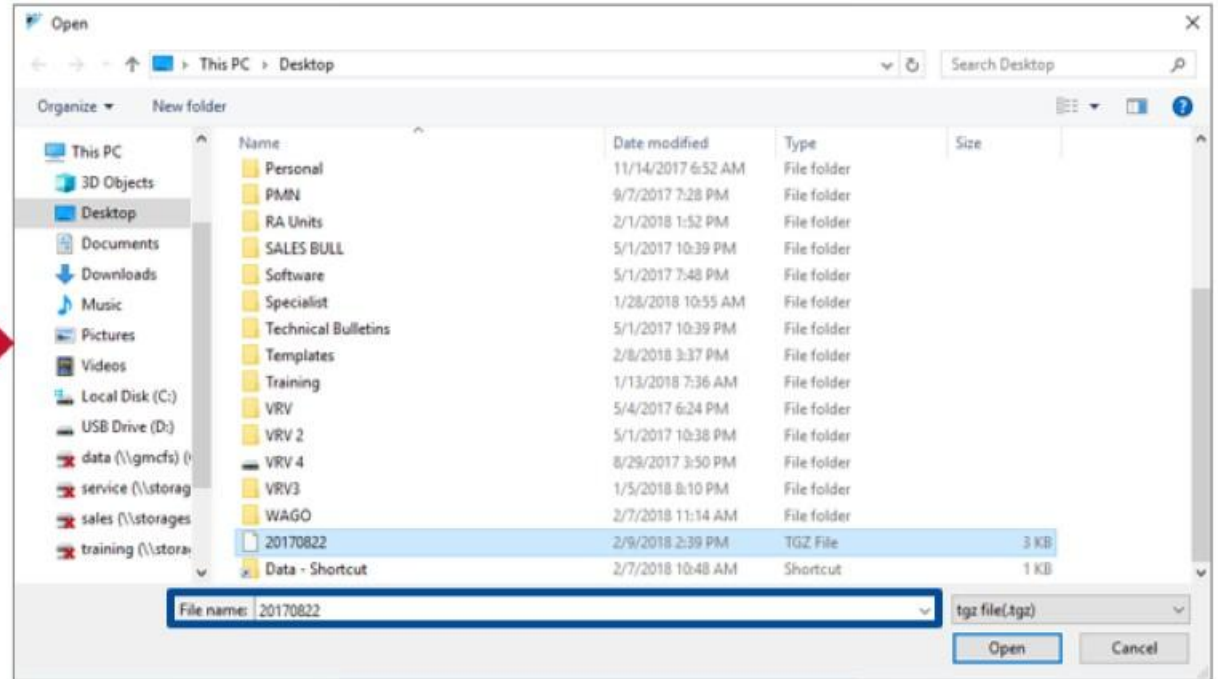
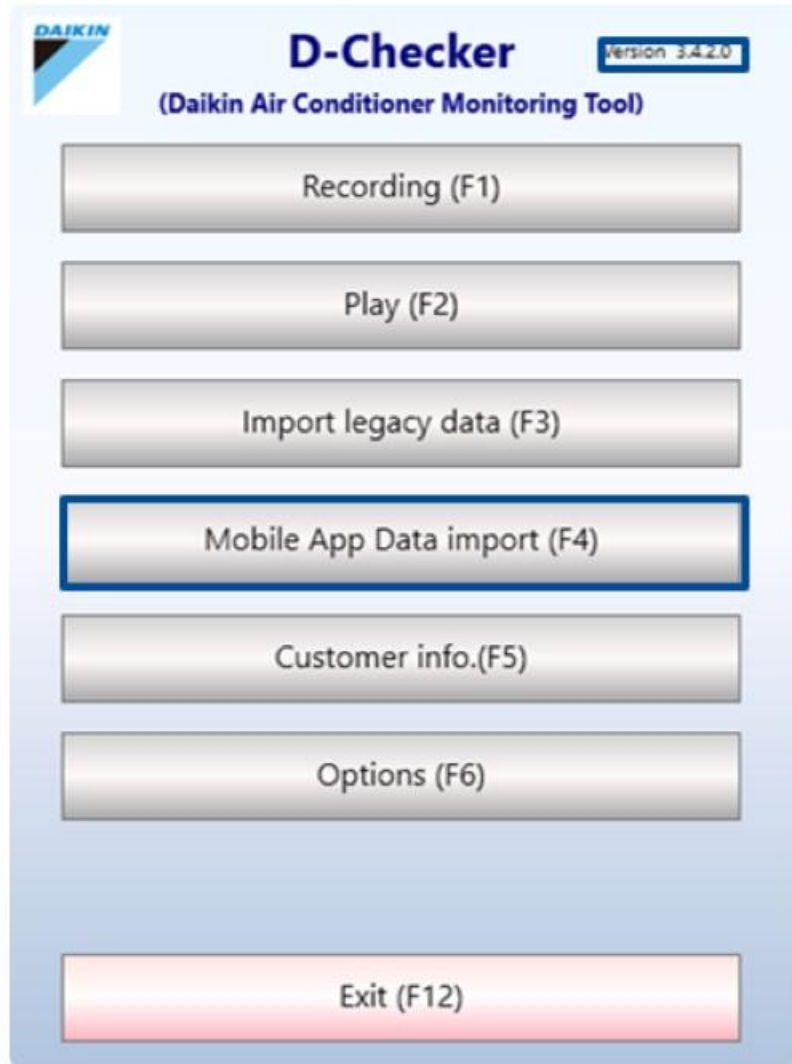

# How To Export .CSV File



**DAIKIN**  
**D-Checker** Version 3.4.2.0  
(Daikin Air Conditioner Monitoring Tool)

Recording (F1)

**Play (F2)**

Import legacy data (F3)

Mobile App Data import (F4)

Customer info.(F5)

Options (F6)

Exit (F12)

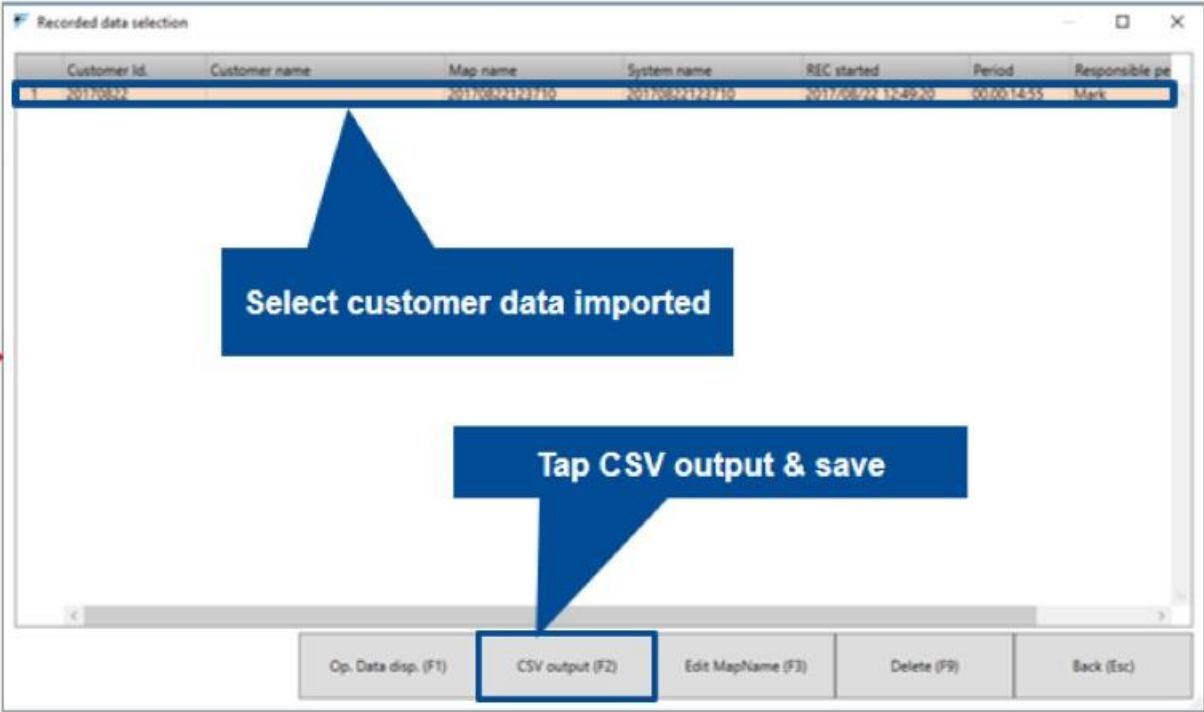

Recorded data selection

Customer Id.	Customer name	Map name	System name	REC started	Period	Responsible pe
20230002		20230002000000	20230002000000	2023/01/22 17:40:00	00:00:14:55	Mark

Select customer data imported

Tap CSV output & save

Op. Data disp. (F1) **CSV output (F2)** Edit MapName (F3) Delete (F9) Back (Esc)



# ***A*** **Heating & Air Conditioning** ***Amana***®



© 2023 Daikin Comfort Technologies North America, Inc.  
Amana® is a registered trademark of Maytag Corporation or its related companies and is used under license.  
All rights reserved.